

# **Series 50 A (M1351A)**

# **Series 50 IP-2 (M1353A)**

# **Fetal Monitors**

INSTRUCTIONS FOR USE

M1353-9001J

Printed in Germany February 2002



# **PHILIPS**

Philips makes no warranty of any kind with regard to this material, including, but not limited to, the implied warranties of merchantability and fitness for a particular purpose. Philips shall not be liable for errors contained herein or for incidental or consequential damages in connection with the furnishing, performance or use of this material.

The information contained in this document is subject to change without notice.

Philips assumes no responsibility for the use or reliability of its software on equipment that is not furnished by Philips.

## **Responsibility of the Manufacturer**

Philips only considers itself responsible for any effects on safety, reliability and performance of the equipment if:

- assembly operations, extensions, re-adjustments, modifications or repairs are carried out by persons authorized by Philips, and
- the electrical installation of the relevant room complies with national standards, and
- the instrument is used in accordance with the *Instructions for Use* or *User's Guide*.

## **Intended Use (M1351A)**

The intended use of this device is to monitor the condition of the fetus by measuring fetal heart rate (FHR), maternal uterine activity and optionally fetal movements simultaneously.

The M1351A is a fetal monitor designed for the antepartum testing area. The fetal heartbeat is detected by an ultrasound transmitter/receiver probe applied to the abdominal wall.

The intended use of this device is to provide information of both FHR and maternal uterine activity on a digital display, on a strip chart recorder and on an interface for optional remote data management.

## **Intended Use (M1353A)**

The intended use of this device is to monitor the condition of the fetus by measuring fetal heart rate (FHR), maternal uterine activity and optionally fetal movements simultaneously.

The M1353A is a fetal monitor designed for the antepartum and intrapartum testing area. The fetal heartbeat may be detected by ECG electrodes connected to the fetal scalp or by an ultrasound transmitter/receiver probe connected to the abdominal wall. The uterine pressure may be detected by a pressure probe connected to the intrauterine pressure via a fluid filled tube or by a pressure probe connected to the abdominal wall.

The intended use of this device is to provide information of both FHR and maternal uterine activity on a digital display, on a strip chart recorder and on an interface for optional remote data management.

The monitor should only be used by, or under the direct supervision of, a licensed physician or other health care practitioner who is trained in the use of fetal and maternal heart rate monitors and in the interpretation of fetal and maternal heart rate traces. US law restricts this device to sale by, or on the order of, a physician.

## Conventions Used in This Guide

---

### **Warning**

**A warning alerts you to a potential serious outcome, adverse event or safety hazard. Failure to observe a warning may result in death or serious injury to the user or patient.**

---

### **Caution**

**A caution alerts you to situations where special care is necessary for the safe and effective use of the product. Failure to observe a caution may result in minor or moderate personal injury or damage to the product or other property, and possibly in a remote risk of more serious injury.**

---

***Note***—A note calls your attention to an important point in the text.



On your monitor, this sign indicates that there is detailed information in this book which you must read before proceeding with your task

© 2002 Philips Medizinsysteme Boeblingen GmbH

All rights are reserved. Reproduction in whole or in part is prohibited without the prior written consent of the copyright holder.



# Contents

<b>1. Overview</b>	<b>1</b>
Introduction	1
About This Guide	1
About the Monitors	2
Major Parts and Keys	5
Recorder Keys	5
Major Keys at a Glance	6
Display Panel	8
<b>2. General Information</b>	<b>11</b>
Introduction	11
Fastening a Belt around the Mother	11
Clipping a Transducer to the Belt	12
Attaching a Patient Module to the Belt	13
Connecting a Transducer or Patient Module to the Monitor	13
Signal Quality	14
Suspected Fetal Demise	14
Marking an Event	15
After Monitoring	17
<b>3. Getting Started</b>	<b>19</b>
Introduction	19
Before Connecting to the Power Supply	19
Connecting to the Power Supply	20
Loading Paper	21
Paper-Out Alert	22
Choosing Paper Speed	22
Setting the Paper Speed	22
Tearing Off the Paper	23
Switching on the Recorder	23
Displaying the Time and Date	24
Setting the Time and Date	24
Mounting the Monitor	25
Fitting the Monitor to a Wall	25
Fitting the Monitor to an Angle Mount	26
Fitting the Monitor to a Cart	27

Fitting the Paper Take-Up Tray . . . . .	28
<b>4. Monitoring FHR and FMP Using Ultrasound . . . . .</b>	<b>29</b>
Introduction . . . . .	29
Ultrasound Measurements . . . . .	29
What You Need . . . . .	30
Getting Started . . . . .	30
Fetal Movement Profile. . . . .	32
Switching FMP On and Off . . . . .	33
FMP Statistics . . . . .	34
Troubleshooting . . . . .	35
<b>5. Monitoring FHR Using DECG . . . . .</b>	<b>37</b>
Introduction . . . . .	37
DECG: Contraindications. . . . .	37
What You Need . . . . .	39
Getting Started . . . . .	40
With DECG legplate M1357A . . . . .	41
With Patient Module M1364A . . . . .	42
Using the DECG Adapter Cable M1362B to Monitor DECG. . . . .	44
With DECG Legplate M1357A . . . . .	44
With Patient Module M1364A . . . . .	47
Monitoring DECG. . . . .	50
Switching Arrhythmia Logic On and Off . . . . .	50
Why use Arrhythmia Logic? . . . . .	51
Removing the Fetal Scalp Electrode . . . . .	51
Troubleshooting . . . . .	52
<b>6. Monitoring Twin FHRs . . . . .</b>	<b>55</b>
Introduction . . . . .	55
Things to Remember During Monitoring. . . . .	55
Monitoring Internally . . . . .	56
Monitoring Externally . . . . .	57
Cross-Channel Verification . . . . .	59
Separating Twin FHR Traces: "Twins Offset" . . . . .	59
Using Keys . . . . .	60
Using the Barcode Reader . . . . .	60
Twins Offset: On . . . . .	61
Twins Offset: Off . . . . .	62
Troubleshooting . . . . .	63

<b>7. Monitoring Uterine Activity</b> . . . . .	<b>65</b>
Introduction . . . . .	65
What You Need . . . . .	65
For External Monitoring . . . . .	65
For Internal Monitoring . . . . .	66
External Toco Monitoring . . . . .	66
Internal Toco Monitoring (IUP Monitoring) . . . . .	67
Troubleshooting . . . . .	68
External Toco . . . . .	68
Internal Toco . . . . .	69
<b>8. Measurements Using External Devices</b> . . . . .	<b>71</b>
Introduction . . . . .	71
Supported External Devices . . . . .	72
Connecting External Devices to the Monitor . . . . .	73
Trace Display on Obstetrical Surveillance Systems . . . . .	74
Monitoring Maternal NIBP . . . . .	75
Example Maternal NIBP Trace . . . . .	76
Monitoring FSpO <sub>2</sub> . . . . .	77
Introduction . . . . .	77
Example FSpO <sub>2</sub> Trace . . . . .	77
Troubleshooting . . . . .	78
FSpO <sub>2</sub> . . . . .	78
External Devices . . . . .	78
<b>9. Monitoring Maternal ECG</b> . . . . .	<b>81</b>
Introduction . . . . .	81
Monitoring Maternal ECG . . . . .	81
To Begin Monitoring . . . . .	82
Using MEEG Transducer M1359A . . . . .	82
Using a Patient Module M1364A . . . . .	82
Cross-Channel Verification . . . . .	84
Troubleshooting . . . . .	85
<b>10. Fetal Heart Rate Alerting</b> . . . . .	<b>87</b>
Introduction . . . . .	87
Alerts . . . . .	87
Recognizing an Alert . . . . .	87
Acknowledging an Alert . . . . .	87
Turning Alerting ON or OFF . . . . .	88

Changing Alert Limits . . . . .	88
<b>11. Non Stress Test Timer . . . . .</b>	<b>91</b>
Introduction . . . . .	91
Setting the NST Timer . . . . .	91
<b>12. Recording Notes . . . . .</b>	<b>93</b>
Introduction . . . . .	93
Recording A Note . . . . .	93
Deleting a Barcode Note . . . . .	94
Recording a Patient's Name . . . . .	94
Recording Several Barcodes as One Note . . . . .	94
Recording Several Barcodes as Separate Notes . . . . .	95
<b>13. Modem Interface Module . . . . .</b>	<b>97</b>
Introduction . . . . .	97
Connecting the Modem Interface Module . . . . .	97
Connecting Peripheral Devices . . . . .	98
Connecting to the Telephone System . . . . .	99
PCMCIA Modem . . . . .	100
Entering and Storing . . . . .	101
Barcode Reader . . . . .	101
Getting Started . . . . .	101
Setting Phone Numbers and Patient ID . . . . .	102
Keeping Patient Data . . . . .	102
Clearing Patient Data . . . . .	103
Clearing Trace Memory . . . . .	103
Storing Fetal Trace Data . . . . .	104
Displaying Memory . . . . .	104
Stopping Storage . . . . .	104
Transmitting Data . . . . .	105
Trace Transmission . . . . .	105
Stopping Transmission . . . . .	105
Troubleshooting and Error Messages . . . . .	106
Error Message 77 . . . . .	106
Error Messages . . . . .	107
Power Failure . . . . .	108
<b>14. Upgrade Key . . . . .</b>	<b>109</b>
Introduction . . . . .	109



Upgrade Procedure .....	109
<b>15. Troubleshooting .....</b>	<b>113</b>
Introduction .....	113
Self Test .....	113
Quick Test .....	114
Parameter Test .....	115
Testing Transducers .....	117
Toco .....	117
Ultrasound .....	117
IUP .....	118
Testing Patient Modules and Legplates .....	118
Testing a Barcode Reader .....	119
Error Messages .....	119
<b>A. Care and Cleaning .....</b>	<b>123</b>
Introduction .....	123
Cleaning the Monitor and Accessories .....	124
Cleaning .....	125
Cleaning Agents .....	126
Disinfecting .....	127
Sterilizing .....	128
Belts .....	128
Storing Recorder Paper .....	129
Preventive Maintenance .....	130
Visual Inspection .....	130
Routine Inspection .....	130
Mechanical Inspection .....	131
Calibration and Electrical Safety Checks .....	131
Disposal .....	131
<b>B. Safety Information .....</b>	<b>133</b>
Introduction .....	133
General Safety Information .....	133
Electrical Safety .....	134
Series 50 A .....	134
Series 50 IP-2 .....	135
ESU, MRI and Defibrillation .....	135
Leakage Current .....	136
Maximum Input/Output Voltages .....	136
Service Socket for Upgrade Key .....	136

Combined Interface Module . . . . .	137
Modem Interface Module . . . . .	138
Protective Earth . . . . .	138
Environment . . . . .	139
Spillage . . . . .	140
Electromagnetic Compatibility . . . . .	140
EMC Testing . . . . .	140
System Characteristics . . . . .	141
Avoiding Interference . . . . .	141
<b>C. Replacing Fuses and Batteries . . . . .</b>	<b>143</b>
Introduction . . . . .	143
Replacing the Batteries . . . . .	143
Replacing the Fuses . . . . .	145
<b>D. Accessories . . . . .</b>	<b>147</b>
Introduction . . . . .	147
Standard Accessories . . . . .	147
Options . . . . .	149
Optional Accessories . . . . .	150
Paper . . . . .	151
Gels . . . . .	151
Heart Rate Transducers and Patient Modules . . . . .	152
Electrodes and Cables . . . . .	152
Disposable Scalp Electrodes . . . . .	153
IUP Transducers . . . . .	153
IUP Catheters . . . . .	154
Domes . . . . .	155
IUP Transducer Holder . . . . .	155
Belts and Buttons . . . . .	155
Barcode Booklets . . . . .	157
Modem Interface Module Barcode Sheet . . . . .	157
Digital Interface Protocol Specifications . . . . .	157
<b>E. Manufacturer's Information . . . . .</b>	<b>159</b>
Manufacturer's Responsibility . . . . .	159
Warranty . . . . .	159
USA Law . . . . .	162
Specifications . . . . .	163
Patient Safety . . . . .	163
Operating and Environmental . . . . .	164

Ultrasound, External and Internal Toco .....	166
Recorder .....	166
Scales .....	167
Testing Facilities.....	167
Declaration.....	168



---

## Introduction

This chapter contains general information about your Instructions for Use and about your fetal monitor. You will learn about:

- The most important functions of your monitor
- The major parts and keys of your monitor.

---

## About This Guide

This book tells midwives, nurses, and other health care professionals how to use the Philips Series 50 A fetal monitor and the Philips Series 50 IP-2 fetal monitor.

It discusses and illustrates all the parameters and features of both monitors. Your monitor may not have every one of these features and may look slightly different to the monitor shown in the illustrations in this guide. A label in the margin of the book will indicate whether the text refers to:

- **Both** the **Series 50 A** and the **Series 50 IP-2** fetal monitors
- The **Series 50 A** fetal monitor **only**
- The **Series 50 IP-2** fetal monitor **only**.

---

## About the Monitors

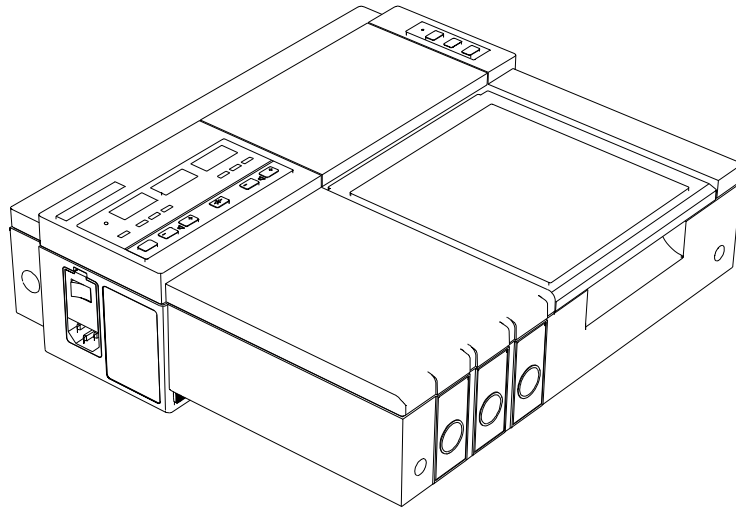

### Series 50 A Dual Ultrasound Model

### Series 50 IP-2

*Series 50 A* The Series 50 A Single Ultrasound model monitors a single fetal heart rate. The Series 50 A Dual Ultrasound model can monitor one or twin fetal heart rates. The Single Ultrasound model looks slightly different from the Dual Ultrasound model. For the illustrations, we have used the Dual Ultrasound model.

*Series 50 IP-2* The Series 50 IP-2 can monitor one or twin fetal heart rates, one using ultrasound and the second using ECG or ultrasound. It looks very similar to the Series 50 A Dual Ultrasound model.

**Note—Not all parameters and features detailed in this manual are available on all monitors**

- Series 50 A* Using the Series 50 A **antepartum** fetal monitor you can monitor
- Fetal heart rate (FHR), externally using ultrasound
  - Uterine activity
  - Fetal pulse oximetry, by connecting an external fetal pulse oximeter to your fetal monitor (optional)
  - Maternal blood pressure, externally, by connecting an NIBP monitor to your fetal monitor (optional)
  - Fetal movement (optional)

Using the Series 50 A Single Ultrasound model you can monitor a single fetal heart rate; the Dual Ultrasound model lets you monitor one or twin fetal heart rates.

With the Series 50 A fetal monitor you can also use an optional Modem Interface Module to send fetal trace information to a Philips obstetrical surveillance system, such as OB **TraceVue**.

- Series 50 IP-2* Using the Series 50 IP-2 **intrapartum** fetal monitor you can monitor Fetal heart rate, including twins

- externally using ultrasound or
- directly using ECG
- Uterine activity
  - externally using an Toco transducer or
  - internally using an IUP catheter
- Maternal heart rate (MHR) using DECG
- Fetal pulse oximetry, by connecting an external fetal pulse oximeter to your fetal monitor (optional)
- Maternal blood pressure, externally (NIBP), by connecting a NIBP monitor to your fetal monitor (optional)
- Fetal movement (optional)

*Series 50 A and Series 50 IP-2* Both monitors offer you the following features:

- Automatic printing of maternal and fetal parameters on the trace paper

- Transmission of maternal and fetal parameters to an obstetrical review system
- Audible and visual alarms
- Twin heart rate separation for ease of interpretation
- Non stress test (NST) timer
- Paper-end alarm
- Significant event marking on the trace paper.



---

## Major Parts and Keys

### Recorder Keys

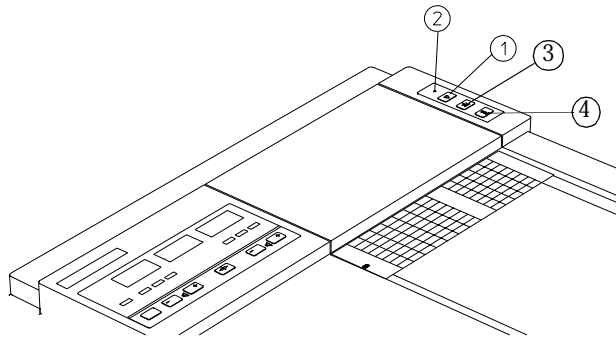

1. **Recorder on/off key** switches the recorder on and off. It also starts the NST timer (switch off the recorder and press the recorder on/off key for two seconds).
2. **Recorder on/off light** is on when the recorder is working. It flashes when the monitor detects five pages or less remaining in the pack, and if the paper runs out.
3. **Event marker key** records events on the paper trace.
4. **Paper advance key** advances paper automatically to the next fold. Tear the paper along the perforations and never pull it to advance it.

## Major Keys at a Glance

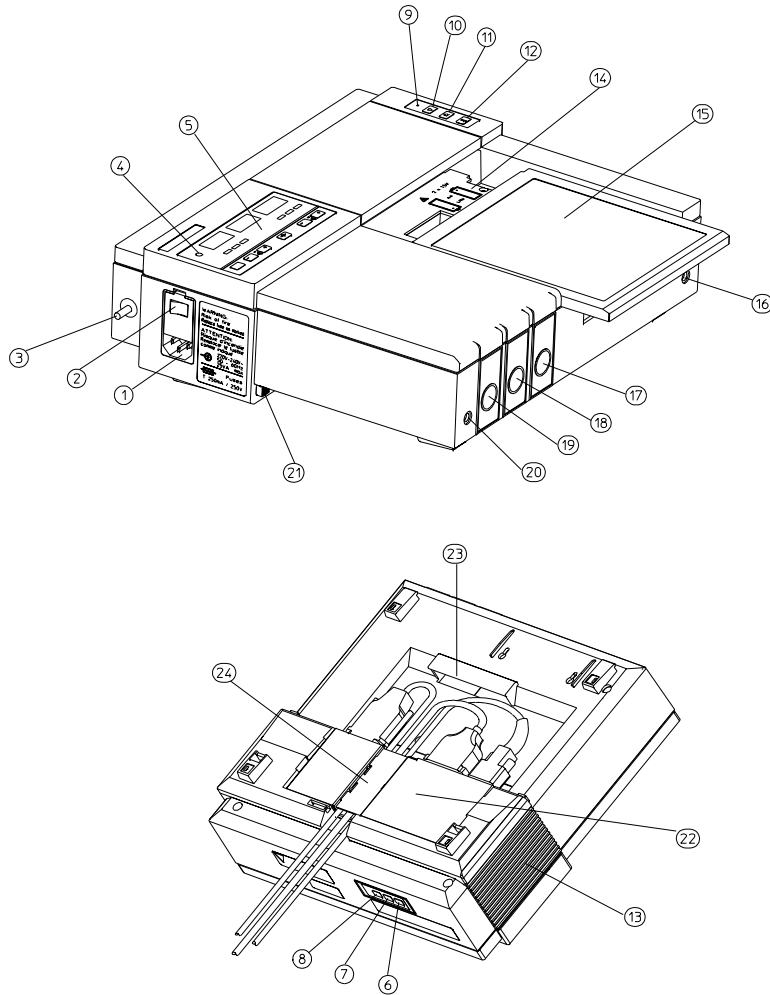

1. Mains socket
2. Monitor on/off switch
3. Equipotential grounding point
4. Monitor on/off light
5. Display panel
6. Time and date key
7. Paper speed key
8. Test key
9. Recorder on/off light
10. Recorder on/off key
11. Event marker key (Alert acknowledge key)
12. Paper advance key
13. Loudspeaker
14. Battery compartment
15. Paper table
16. Service socket
17. *Series 50 A:* US2 Socket (not present on Single Ultrasound model)  
*Series 50 IP-2:* US2/ECG Socket
18. Toco socket
19. *Series 50 A:* Single Ultrasound Model: US Socket  
Double Ultrasound Model: US1 socket  
*Series 50 IP-2:* US1 socket
20. Socket for remote event marker
21. Lock-release button
22. Combined interface module
23. Integrated carrying handle
24. Cable clamp

## Display Panel

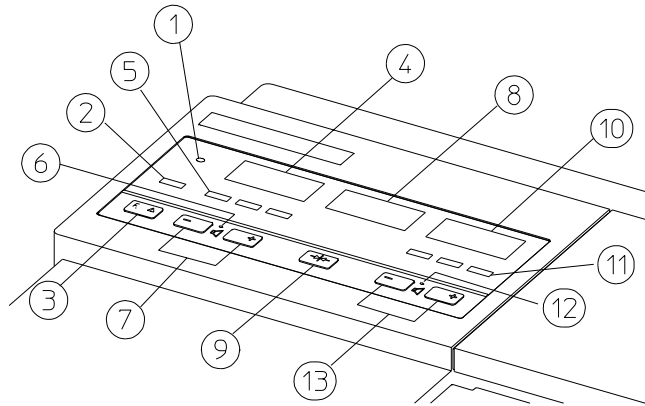

1. **Monitor on/off light**
2. **Telemetry indicator** is on when the fetal ultrasound telemetry receiver is connected and switched on
3. **Function key:** selects menus for twins offset, FMP and logic
4. **US/US1 display.** Shows the FHR detected by the US transducer
5. **US/US1 signal quality indicator** shows the quality of the heart rate signal detected by the US transducer:
  - Green (good)
  - Yellow (fair to potentially poor)
  - Red (unacceptable)
6. **US/US1 speaker light** is on when the US/ US1 heartbeat is the one you hear
7. **US/ US1 volume keys** set the volume and select the US channel to which you are listening. Use them also to change current setting of FMP, twins offset, logic, and FHR alert.
8. **Toco display** shows uterine activity
9. **Toco baseline key** zeros the Toco display and trace to 20 units when you are monitoring uterine activity externally or 0 units when you are monitoring uterine activity internally

10. **US2/ECG display** shows the FHR detected by the US2 or DECG transducer.
11. **US2/ECG signal quality indicator** shows the quality of the signal detected by the US2 or DECG transducer.
12. **US2/ECG speaker light** is on when the US2 or DECG heartbeat is heard.
13. **US2/ECG volume keys** set the volume and select the US2 or DECG heartbeat.



# General Information

---

## Introduction

This section contains information about tasks you will need to perform regularly. You will learn how to:

- Fasten a belt around the mother
- Attach a transducer or patient module to the belt
- Connect a transducer or patient module to the monitor
- Mark a significant event on the trace paper
- Be aware of possible fetal demise
- Care for the monitor and accessories after monitoring.

---

## Fastening a Belt around the Mother

1. Place the transducer belt across the bed, ensuring that the fixing button will face away from the mother when it is fastened. Use two belts if you are monitoring uterine activity and FHR at the same time.
2. Lie the mother on the bed and arrange the belt around her until it is tight but still comfortable.
3. Fasten the belt by pushing the fixing button through the overlapping section of the belt.

## Clipping a Transducer to the Belt

Ensure that the fixing button and the loose ends of the belt are at the patient's side.

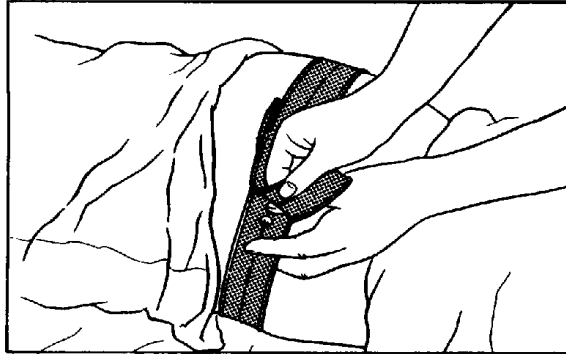

---

## Clipping a Transducer to the Belt

When you have positioned a transducer satisfactorily, you can clip it to the belt using the snap-shut mechanism. The clip is designed to allow the transducer to slide along the belt for easy repositioning.

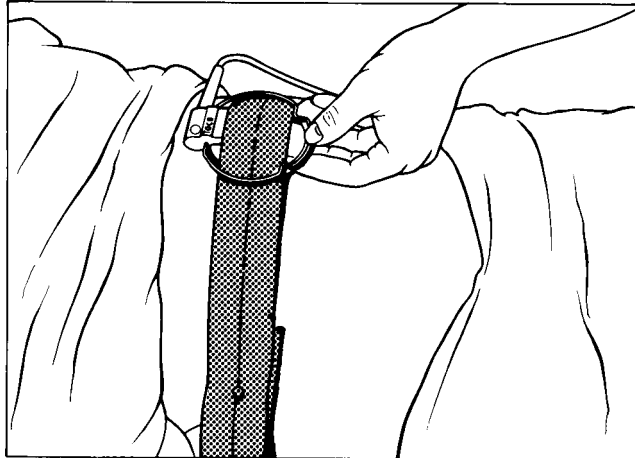

Alternatively, you can fix a button to the transducer and use this to attach



the transducer to the abdominal belt. See the Installation Note that comes with the Transducer Adapter Button for assembly instructions,

---

## Attaching a Patient Module to the Belt

You can attach a patient module to the belt by pushing the fixing knob (1) on the patient module through one of the holes in the belt.

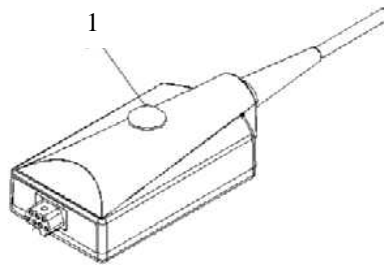

---

## Connecting a Transducer or Patient Module to the Monitor

To connect a transducer or patient module to the monitor, first switch on the monitor and the recorder. When you connect a transducer or a patient module to either the US/US1 socket, the Toco socket, or the US2/ECG socket:

- The dashes in the corresponding digital display will go out.
- The signal quality light for the heart rate display turns red, as the transducer or patient module is not yet receiving a good signal from the patient.
- The monitoring mode will be printed on the trace paper, and repeated every three to four pages. Depending on the parameter you are monitoring, this could be US, US1, US2, DECG, TOCO int or TOCO ext.

- You will hear the fetal heartbeat from the loudspeaker.

If the Fetal Scalp Electrode and the electrode wires are connected correctly and a good signal is being produced, the signal quality indicator should be green. If an inadequate signal is being produced, or there is a bad contact, the signal quality indicator will be red. The message **noP** *may* also be displayed. See Chapter 15, “Troubleshooting,” for more details.

---

**Warning**

**NEVER immerse a transducer in liquid when it is connected to the fetal monitor.**

---

---

## Signal Quality

During monitoring, if the signal quality indicator fluctuates between red, yellow and green, it does not necessarily mean that the transducer needs repositioning. The fluctuation may be caused by fetal movement. Allow time for the signal to stabilize before deciding whether to reposition the transducer (ultrasound) or apply a new electrode (ECG). A trace is possible when the indicator is yellow, but for the best trace it should be continuously green.

---

## Suspected Fetal Demise

Be very careful when interpreting a trace if you suspect fetal demise. The maternal heartrate may be atypically high and therefore confused with that of a live fetus. Apparent fetal movement may also be detected by the monitor but this may be a result of maternal movement causing the fetus to move within the amniotic fluid.

Please refer to “Cross-Channel Verification” on page 84.

---

## Marking an Event

Use the event marker key or the remote event marker to record significant events on the trace paper (for example, when pain medication is administered or when the mother changes position). The mother can use the remote event marker to mark events herself. To mark an event on the trace paper you can either:

- Press the event marker key “Mark” on the monitor (1)

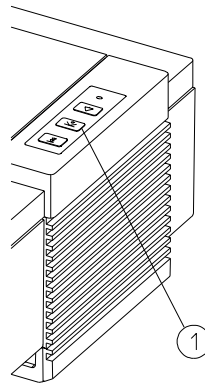

- Or press the button on the remote event marker. The remote event marker is connected to the monitor via the socket to the left of the US/US1 transducer socket.



## Marking an Event

A small arrow is printed on the heart rate scale on the trace paper. The arrow starts with the peak to show the exact time when the key or button has been pressed.

If the key or button is not released, a black bar is printed on the paper. The width of the bar corresponds to the length of time the key or button is pressed.

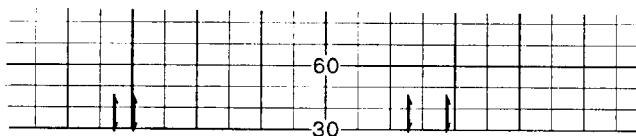

pop03ca.tif

---

## After Monitoring

1. Switch off the recorder.
2. Press and release the paper advance key to advance the paper automatically to the next fold.
3. Remove the transducer from the patient and, using a soft tissue, remove any gel from it.
4. Tear off the paper at the fold.  
Don't pull on the paper to advance it and only tear off the paper at the fold.
5. Switch off the monitor.

After Monitoring

---

## Introduction

This chapter tells you how to set up your monitor to begin monitoring your first patient. You will learn how to:

- Check that your monitor is set for the correct voltage for your country
- Connect the monitor to the power supply and switch it on
- Set the time and date
- Load paper into the recorder and fit the paper take-up tray
- Choose the paper speed
- Mount the monitor on an angle mount, cart, or wall.

---

## Before Connecting to the Power Supply

Operate the monitor from an ac power source of:

- 100 V - 120 V ( $\pm 10\%$ )
- 220 V - 240 V ( $\pm 10\%$ )

and 50 to 60 Hz ( $\pm 5\%$ )

The maximum power consumption is 25 VA.

Before connecting the monitor to the power supply, make sure that the voltage label on the side panel of the monitor (1) shows the correct setting for your country.

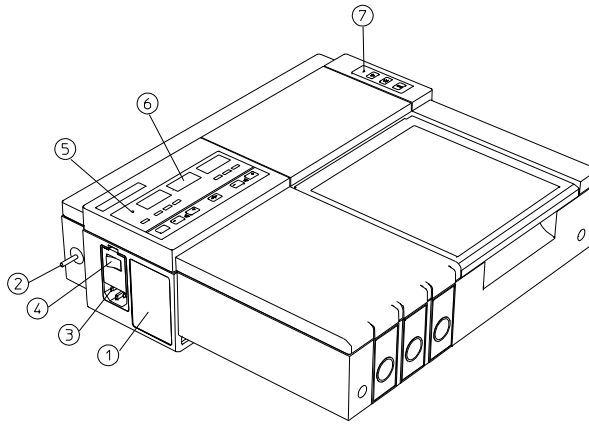

If you intend to connect the monitor to other equipment, connect the equipotential grounding point (2) to earth potential.

---

## Connecting to the Power Supply

Connect the power cord to the mains socket. Press the monitor on/off switch to turn the monitor on.

- The monitor on/off light will be turned on and the digital displays will become visible.
- You will hear a click from the loudspeaker.
- The recorder on/off light may be turned on. This means that the recorder was still on when the monitor was last switched off.
- The monitor will carry out a self-test.  
See Chapter 15, “Troubleshooting,” for details of the self test and the error messages that may be displayed.
- We recommend that you carry out a quick test and a parameter test the first time you switch on your monitor. See Chapter 15, “Troubleshooting,” for instructions on how to carry out these tests.



## Loading Paper

To load a new pack of paper:

1. If the recorder is on, press the recorder on/off switch to turn it off.
2. Press the handle (1) to unlock the paper table and then pull the table forward to open it fully.

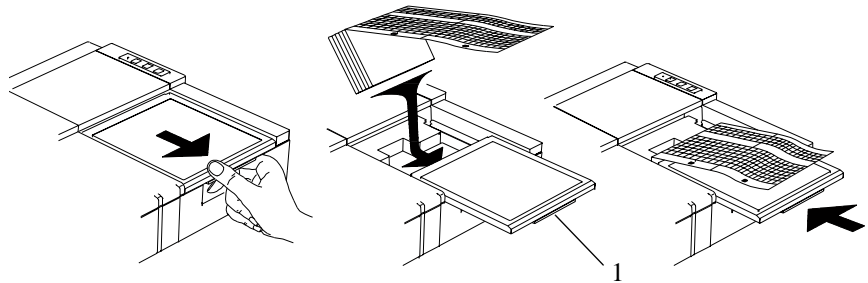

pega45\_bw.hpg

3. Lift out any remaining paper.
4. Place the new pack of paper in the tray with the bottom side down. The bottom side is indicated by the word STOP printed on the final page of the new pack.
5. Unfold the top page of the pack and position the uterine activity scale on the right.
6. Slide the pack into the tray.
7. Push the paper table back until it “clicks” closed.
8. Press the recorder on/off key to switch on the recorder. If the recorder on/off light flashes after the paper is loaded and the recorder is switched on, the drawer is not closed properly. The paper advances quickly for 2 cm and then returns to the set speed. The time, the date, and the paper speed are printed on the paper. Refer to the section “Error Messages” on page 119 if you have any trouble loading and using the trace paper.

---

**Caution**

**Using recorder paper that is not approved by Philips can damage the monitor. This type of damage is not covered by warranty.**

---

## Paper-Out Alert

Each pack of paper has 150 numbered pages. The last five pages have countdown numbers (5, 4, 3, 2, 1). The recorder on/off light flashes when the monitor detects that there are five pages or fewer remaining in the pack. (If you switch on the recorder or press the paper advance key when there are fewer than five pages remaining, it may take two pages before the recorder on/off light flashes.) Load a new pack as soon as possible.

If the recorder runs out of paper a 10-second audible paper-out alert is sounded. For instructions on how to disable the paper-out alert see the Service and Installation Guide for your monitor.

## Choosing Paper Speed

You can choose a paper speed of 1, 2, or 3 centimeters per minute (cm/min). The default for North America is 3 cm/min; the default for other countries is 2 cm/min.

The ACOG technical bulletin on FHR monitoring states that “*accurate pattern recognition is difficult if not impossible at 1 cm/min and that 1 cm/min is only recommended for more economic screening. When FHR abnormalities arise, the faster paper speeds will enhance FHR pattern recognition*”.

Additionally, because a change in paper speed results in a change in the appearance of an FHR trace, you are advised to ensure **ALL** monitors in your institution are set at the same speed.

## Setting the Paper Speed

Use the paper speed key to display the current paper speed and to return to the normal display. You also return to the normal display automatically if you don't press any key for a few seconds. Use the volume keys to change the speed. When you return to the normal display, the new paper speed is set, and the time, date, speed, and monitoring modes are printed on the paper.

To set the paper speed:

1. Press and release the paper speed key  to display the current speed.
2. Press the plus key or the minus key to set the speed.
3. Press and release the paper speed key to return to the normal display.

## Tearing Off the Paper

To tear off the trace paper after monitoring:

1. Turn off the recorder.
2. Press and release the paper advance key. This advances the paper automatically to the next perforation.
3. When the paper stops advancing, tear off the trace paper along the perforation.

NEVER pull on the paper to advance it.  
ALWAYS tear off the paper at the perforation.

---

## Switching on the Recorder

Press the recorder on/off key to switch on the recorder. When you switch on:

- The recorder on/off light comes on.
- The paper advances quickly for 2 cm and then returns to the set speed.
- The time, date and paper speed are printed on the trace paper.
- The current monitoring modes (if any transducers are connected to the monitor) are printed.

The monitor prints the time, date, paper speed and monitoring modes when first switched on, every ten minutes after, and if the monitoring modes change.

---

## Displaying the Time and Date

The date and time are printed on the trace. You can choose from a variety of standard date and time formats, such as 12 hour format or 24 hour format, US or European date format. If you have a barcode reader you can change the time and date display format by scanning the desired format from the barcode sheet. If you do not have a barcode reader, you can set the desired format using a service setting. See the Service and Installation Guide for your monitor for instructions.

### Setting the Time and Date

The clock key on the back of the monitor is used to display the current time and date and to return to the normal display. You will also be returned automatically to the normal display if you do not press any key for a number of seconds. Use the volume keys to set the time and date in a similar way as you would with a digital watch.

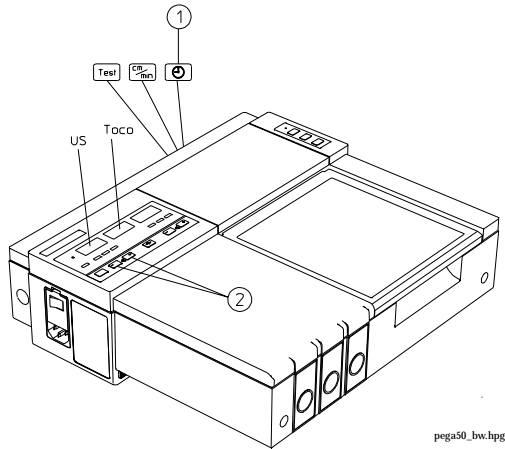

1. Press and release the clock key (1) to display the current time in the US1/Toco display. The US/US1 display flashes to show that the hour setting can be changed.
2. Press the plus key or the minus key to change the setting.
3. Press and release the clock key again and the Toco display will flash to show that the minutes setting can be changed.
4. Press the plus key or the minus key to change the setting.

5. Repeat the procedure:
  - to set the month (in North America) or the day (in other countries)
  - to set the day (in North America) or the month (in other countries)
  - to set the year.

Press and release the clock key to return to the normal display. When the paper advances, check that the correct date is printed on the paper.

---

## Mounting the Monitor

---

### **Warning**

**Make sure that all four feet are firmly in place when you mount the monitor**

---

You can fit the monitor on the wall, on an angle mount, or on a cart.

### Fitting the Monitor to a Wall

To mount the monitor on the wall:

1. Affix the mounting plate to the wall according to the instructions supplied with it.
2. Hold the monitor at a slight angle and sit the front feet in the slots on the mounting plate (A). The small step on each foot helps you to fit it firmly into place.
3. Push the monitor upright until the back feet “click” into the slots (B).

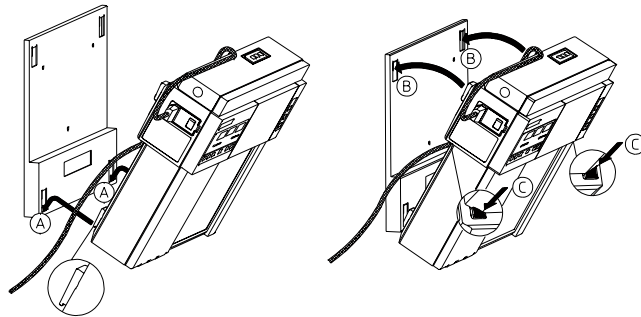

pega41\_bw.hpg

To remove the monitor from the wall mounting plate, hold the monitor in both hands, press both lock-release buttons (C) simultaneously and lift it out.

### Fitting the Monitor to an Angle Mount

Fit an angled mount to the cart according to the instructions supplied with the angle mount. To fit the monitor to the angled mount:

1. Hold the monitor at a slight angle and sit the front feet in the slots (A). The small step on each foot helps you to fit it firmly in place.
2. Lower the monitor until the back feet “click” into the slots (B).

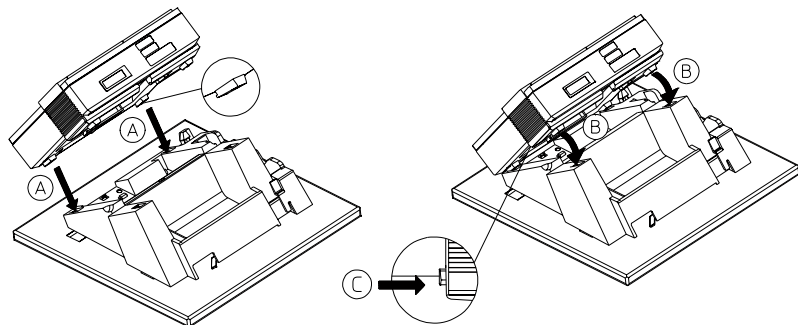

angle5\_bw.hpg

---

**Warning**

**Make sure that all four feet are firmly in place when you mount the monitor**

---

To remove the monitor from the angled mount, hold the monitor in both hands, press both lock-release buttons (C) simultaneously and lift it out.

## Fitting the Monitor to a Cart

To fit the monitor to the cart:

1. Hold the monitor at a slight angle, sit the front feet in the front slots along the top of the cart. The small step on each foot will help you to fit it firmly in place.
2. Lower the monitor until the back feet “click” into the back slots.

To remove the monitor from the cart, hold the monitor in both hands, press both lock-release buttons (C) simultaneously and lift it out.

---

## Fitting the Paper Take-Up Tray

To fit the paper take-up tray (option 1AC) to the monitor:

1. Slide the tray between the guides (A) until the pins locate in the holes (B).
2. Pull the tray forward to lock it in place (C).

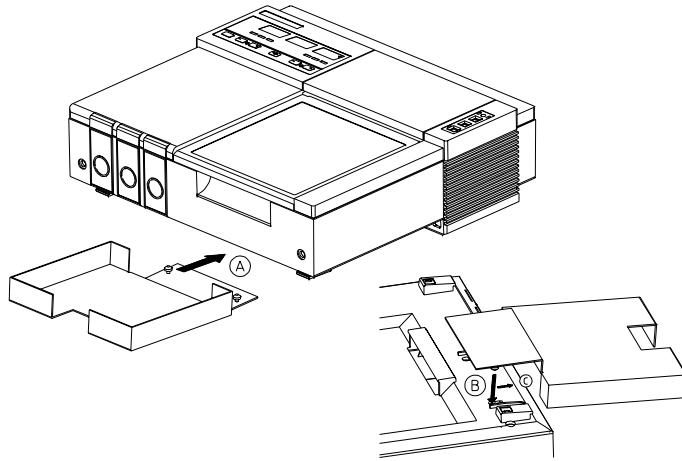

pega31\_bw.hpg



# Monitoring FHR and FMP Using Ultrasound

---

## Introduction

In this chapter you will learn how to:

- Monitor a single heart rate using ultrasound
- Monitor fetal movements using ultrasound
- Switch FMP monitoring on and off.

---

## Ultrasound Measurements

To monitor FHR externally, an ultrasound transducer is clipped to a belt around the mother's abdomen. The transducer directs a low-energy ultrasound signal towards the fetal heart and detects the reflected signal. Monitoring using ultrasound is recommended from the 25th week of gestation for non-stress or normal routine fetal monitoring.

If your monitor has the fetal movement profile option, indicated by this label underneath the ultrasound socket, it can also detect fetal movements and display the resulting fetal movement profile (FMP) on the trace.



*Series 50 IP-2  
Only*

If you simultaneously monitor a single FHR using both ultrasound and DECG, the ultrasound trace is delayed by approximately two to three beats per minute. See Chapter 5, "Monitoring FHR Using DECG," for instructions on monitoring using DECG.

Performing ultrasound imaging or Doppler flow measurements together with the ultrasound fetal monitoring may cause false FHR readings, and

the trace recording may deteriorate.

---

## What You Need

- Ultrasound transducer
- Gel
- Transducer belt and button

---

## Getting Started

---

### **Warning**

**NEVER immerse the ultrasound transducer in liquid when it is connected to the monitor. If you intend to use an ultrasound transducer in water, you must use a waterproof telemetry system.**

---

1. Fasten the belt around the patient.
2. Switch on the monitor and the recorder.
3. Connect the transducer to the US/US1 socket. If you are monitoring a single fetus, you must unplug all unused transducers and patient modules.
4. Find the fetal heart position by palpation, auscultation or ultrasound imaging.

5. Apply a small amount of ultrasound gel in a thin layer to the transducer.

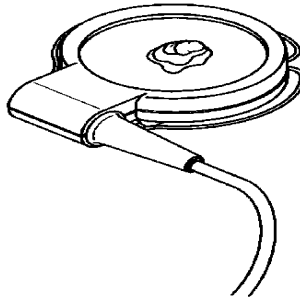

6. Apply the transducer to the patient, working it in a circular motion to ensure the gel layer makes good contact.
7. When you have a good signal and the signal quality indicator has shown green for at least 30 seconds, clip the transducer in position on the belt.

---

**Warning**

**Periodically compare the mother's pulse with the signal coming from the monitor's loudspeaker to ensure that you are monitoring fetal heart rate. Do not mistake a doubled maternal heart rate for FHR.**

---

We recommend that you monitor maternal heart rate as well as FHR, especially during the later stages of labor. For information on setting FHR alerting limits, see Chapter 10, "Fetal Heart Rate Alerting."

*Series 50 IP-2  
Only*

When you monitor maternal heart rate simultaneously with FHR, cross-channel verification alerting warns you if maternal and fetal heart rates coincide.

---

**Caution**

**Using ultrasound gel that is not approved by Philips may reduce signal quality and may damage the transducer. This type of damage is not covered by warranty.**

---

---

## Fetal Movement Profile

The Fetal Movement Profile parameter, often abbreviated to FMP, detects fetal movements via an ultrasound transducer plugged into the US1/US socket. If your monitor has this feature, you'll see this label



underneath the US1 or US socket.

The transducer detects gross fetal body movements: eye movements are not detected and movement of the feet and hands may not be detected. Positioning or repositioning of the transducer is recorded as fetal movement; maternal movement, excessive fetal breathing or fetal hiccups may also be recorded as fetal movement. You can mark these artifacts on the trace paper using either the remote event marker or the event marker key as described in “Marking an Event” on page 15. Ignore these movements when you interpret the FMP. When monitoring twins, remember that movements recorded for twin 1 may also be caused by movement of twin 2.

The resulting fetal movement profile (FMP) appears as “activity blocks” (A) along the top of the Toco Scale, the length of each block showing the duration of the activity.

FMP is activated every time you plug the ultrasound transducer into the US1/US socket. If you look at the trace, you'll see FMP was printed on

the trace to mark the start of the FMP statistic.

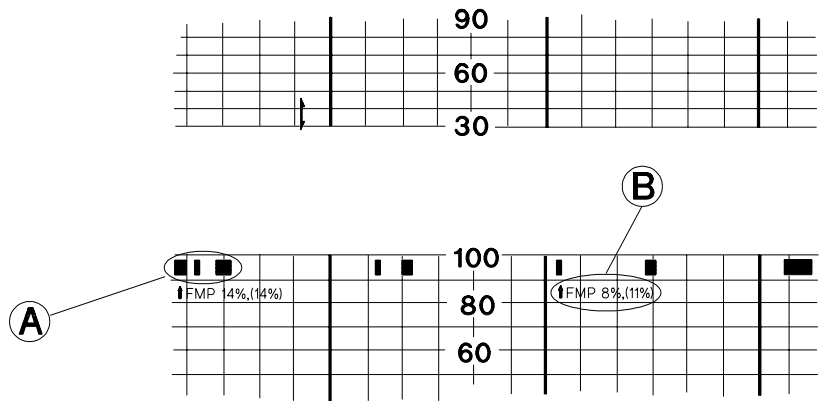

## Switching FMP On and Off

Switching the monitor on also switches FMP on. You must connect an ultrasound transducer to the US/US1 socket before you can change the FMP setting. FMP can be switched on and off using either the function keys or the optional barcode reader.

### Using Keys

1. Press the function key **F.△** repeatedly until the digital display shows FMP. The signal quality indicator shows:
  - Red if FMP is off
  - Green if FMP is on.
2. Press the plus key or the minus key to turn FMP on or off.
3. Press and release the function key to return to the normal display. You will also be returned to the normal display if you do not press any key for a number of seconds. Notice that FMP is printed on the trace paper.

When you switch off the monitor it will automatically revert to the default setting, FMP on.

### Using the Barcode Reader

Enter **FMP Off** or **FMP On** from the barcode sheet

**Note—FMP is switched off whenever a Series 50 T Fetal Telemetry System connected to the monitor is switched on. If you switch off or disconnect the telemetry system, FMP is automatically switched back on again when the telemetry system is switched off or unplugged. If you want to monitor FMP with a Series 50 T Fetal Telemetry System (and you have the correct software revision and interface for Telemetry FMP installed) switch FMP on by using either the function key or the barcode method.**

## FMP Statistics

FMP statistics (B) are printed below the activity blocks every 10 minutes.

The first value shows the percentage of detected fetal movements in the previous 10 minutes, and the value in parentheses shows the percentage of detected fetal movements since the recorder was switched on. During the first 10 minutes of monitoring, the values will be identical.

If you plug an ultrasound transducer into the US/US1 socket, or if FMP is switched on, FMP statistics start again from zero.

The FMP output activates after about half a minute of valid heart rate signals (green or yellow signal quality indicator) to minimize transducer positioning artefact. ↑FMP is printed on the paper to mark the starting point of the FMP statistic.

## Troubleshooting

Problem	Possible Causes	Solutions
Erratic trace Erratic display	Fetal arrhythmia Obese patient Transducer wrongly positioned  Belt loose Too much gel Very active fetus Maternal movement Insufficient gel	None None Reposition transducer until signal quality indicator is green Tighten belt Remove excess None Relax the patient Use recommended amount
Signal quality indicator is red continuously	Transducer wrongly positioned FHR less than 50 bpm	Reposition transducer until signal quality indicator is green None
Questionable FHR	Recording MHR by mistake Recording spurious periodic signals when the transducer is not applied to the patient	Reposition transducer
	FHR exceeds 300 bpm	FHR is half-counted (for example 320 bpm is recorded as 160 bpm)
FHR not recorded	FHR is less than 50 bpm or between 240 - 300 bpm	None
Light or no trace	Wrong paper or dirty printhead	Use recommended paper or clean printhead
End of paper noted when pack not finished	Bad paper feed or wrong paper	Check paper feed and use recommended paper
Error message is displayed		See Chapter 15, "Troubleshooting" for a table of error messages, their causes and their solutions.
If you suspect the signal from the transducer		Carry out the Parameter Test as described on page 115.
If you suspect the signal from the recorder or display		Carry out the Quick Test as described on page 114.





# Monitoring FHR Using DECG

---

## Introduction

### *Series 50 IP-2 Only*

This chapter describes how to monitor a single fetal heart rate directly using the Series 50 IP-2 fetal monitor. You will learn how to:

- Apply and remove a Fetal Scalp Electrode
- Monitor fetal DECG using the DECG adapter cable with a DECG legplate transducer or a DECG patient module
- Monitor fetal DECG using the traditional open-wire method with a DECG legplate or a DECG patient module
- Turn arrhythmia logic on and off

---

## DECG: Contraindications

The direct mode of monitoring uses a Fetal Scalp Electrode to assess the fetal heart rate and variability. It can only be used when the membranes are ruptured and the cervix is sufficiently dilated during the intrapartum period. Because the tip of the electrode penetrates the fetal epidermis, the possibility of trauma, hemorrhage, and infection exists. Use the electrode only under aseptic conditions. Do not apply the electrode:

- To the fetal face, to the fontanel, or to the genitalia
- When placenta previa is present
- When you cannot identify the portion of the fetal body to which you intend to apply the Fetal Scalp Electrode
- Before the membranes are ruptured
- If genital infection exists

- When the patient is less than two centimeters dilated
- When the fetal station is less than minus two.

If you are monitoring one FHR using both ultrasound and DECG, the ultrasound trace will be delayed by approximately 2 to 3 bpm.

Unless you suspect fetal arrhythmia, be sure that arrhythmia logic is on when monitoring FHR using DECG. (See “Switching Arrhythmia Logic On and Off” on page 50 in this chapter for details.)

For information on setting FHR alerting limits see Chapter 10, “Fetal Heart Rate Alerting.”

---

## What You Need

- If you are measuring fetal DECG using the traditional open-wire\* method with a legplate transducer:
  - DECG legplate transducer (M1357A)
  - Transducer leg belt and button
  - Open-wire Fetal Scalp Electrode (15133A/15133C).
  
- If you are measuring fetal DECG using the traditional open-wire\* method with a patient module:
  - ECG patient module (M1364A)
  - Adapter cable (M1362A)
  - Pre-gelled Pad Electrode (40493E)
  - Open-wire Fetal Scalp Electrode (15133A/15133C).
  
- If you are measuring fetal DECG using the DECG leg plate adapter cable M1362B with a legplate transducer:
  - DECG legplate transducer (M1357A)
  - DECG adapter (M1347A)
  - DECG leg plate adapter cable (M1362B)
  - Transducer leg belt and button
  - Pre-gelled Pad Electrode (M1349A)
  - Fetal Scalp Electrode (15133E/15133D).

If you are measuring fetal DECG using the DECG leg plate adapter cable M1362B with a patient module:

- ECG patient module (M1364A)
- DECG leg plate adapter cable (M1362B)
- Pre-gelled Pad Electrode (M1349A)
- Fetal Scalp Electrode (15133E/15133D).

---

\*. Not available in all countries.

---

## Getting Started

Prepare as you would for a routine sterile vaginal examination. Ensure that the fetus is in a position to be monitored by DECG. Attach the electrode to the fetus as described in the instructions that come with the Fetal Scalp Electrode.

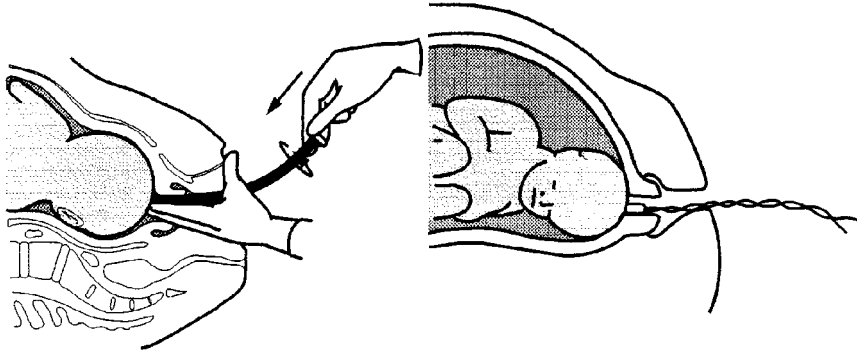

Attaching the Fetal Scalp Electrode

Fetal Scalp Electrode Attached

---

### **Warning**

**Do not insert the fetal scalp electrode wires into the mains plug.**

---

---

## Using the Traditional Open-wire Method to Monitor DECG (applicable to Fetal Scalp Electrode 15133A and 15133C)

### With DECG legplate M1357A

To monitor fetal DECG using the traditional open-wire method and a DECG legplate M1357A , follow these instructions.

1. Fasten the belt around the patient's upper thigh. Ensure that the belt is correctly attached to prevent tension in the cable from pulling on the Fetal Scalp Electrode and injuring the fetus.
2. Slide the transducer under the belt, pointing the connectors towards the abdomen. To get the best signal the transducer must have good contact to the mother's skin. Do not apply Redux creme or any other conductive gel to the silver plate on the bottom of the DECG transducer.

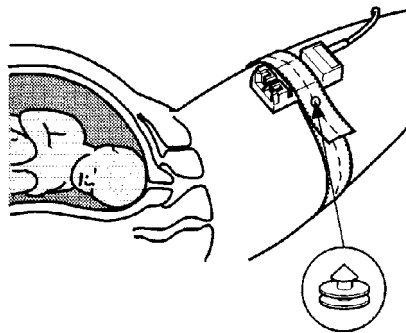

3. Connect the Fetal Scalp Electrode wires to the DECG transducer.

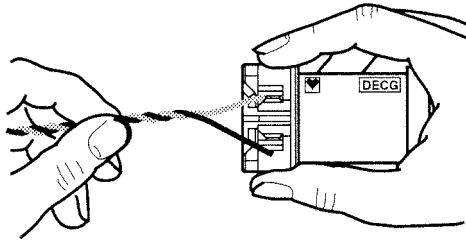

4. You are now ready to begin monitoring DECG: see the section “Monitoring DECG” for your next step.

### With Patient Module M1364A

To monitor fetal DECG using the traditional open-wire method and either an ECG-only patient module (M1364A), follow these instructions.

1. Fix the DECG cable clip (2) to a pre-gelled electrode 40493E (1).
2. Connect the Fetal Scalp Electrode wires (3) to the DECG cable clip as shown below:

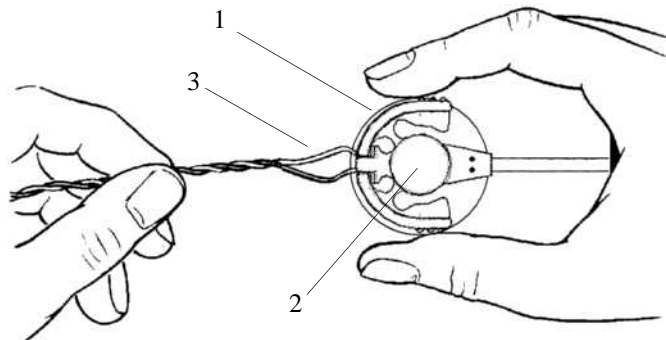

3. Peel the backing from the electrode (40493E) and affix it to the mother’s thigh. A good contact between the electrode and the mother’s skin will improve the FHR signal. To get the best signal, ensure that the skin is clean and dry before attaching the electrode. Ensure that the electrode is correctly positioned to prevent tension

in the cable from pulling on the Fetal Scalp Electrode and injuring the fetus.

4. Attach the pink connector **(1)** on the DECG cable to the ECG pink connector **(1)** on the patient module.

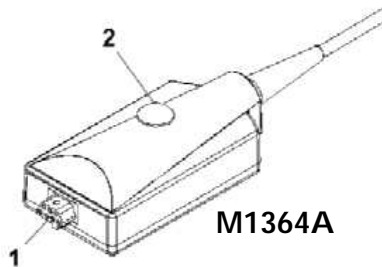

5. Position the patient module under the abdominal transducer belt wherever it is comfortable for the mother, securing it to the belt using the fixing knob **(2)**.
6. You are now ready to begin monitoring DECG: see the section “Monitoring DECG” below for your next step.

---

## Using the DECG Adapter Cable M1362B to Monitor DECG (Applicable to Fetal Scalp Electrode 15133E/D)

### With DECG Legplate M1357A

To monitor fetal DECG using the DECG leg plate adapter cable (M1362B) and a DECG legplate transducer (M1357A), follow these instructions.

1. Connect the DECG adapter (M1347A) to the DECG legplate transducer (M1357A):
  - With the finger and thumb of one hand, press in the spring clips on the legplate.

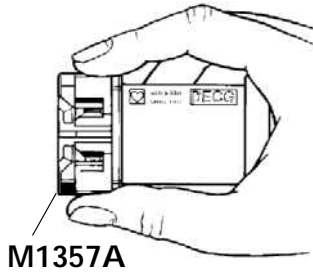

- Fit the DECG adapter (M1347A) onto the legplate and release the spring clips to lock the adapter into place.

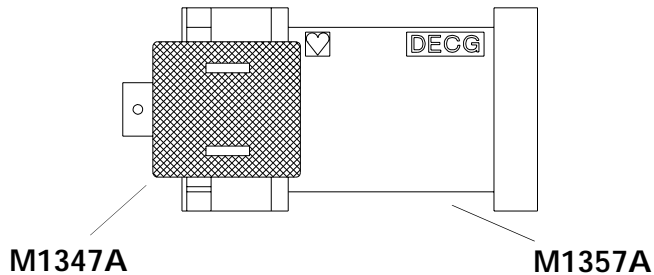



2. Secure the legplate transducer under the abdominal belt or under the leg belt. To get the best signal the transducer must have good contact to the mother's skin. Do not apply Redux creme or any other conductive gel to the silver plate on the bottom of the DECG transducer.

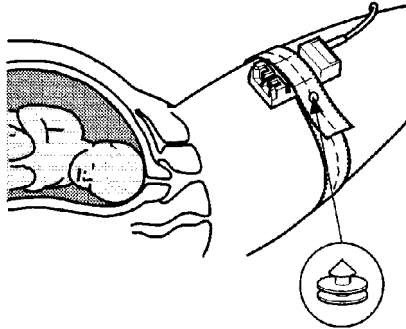

3. Attach a pre-gelled electrode (M1349A) to the DECG leg plate adapter cable (M1362B).

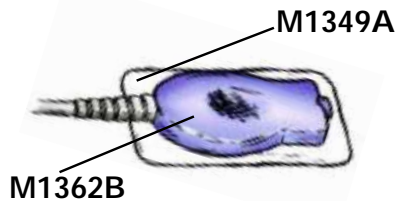

4. Connect the DECG leg plate adapter cable (M1362B) to the DECG adapter (M1347A).

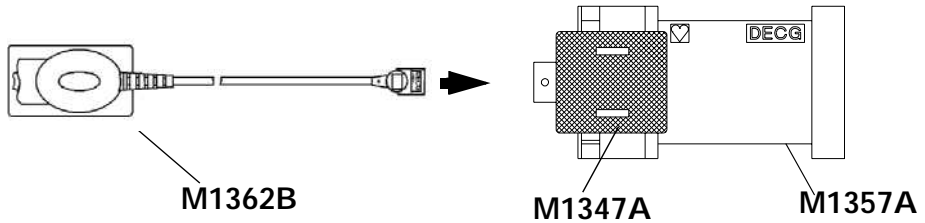

5. Connect the Fetal Scalp Electrode (15133E/D) to the DECG leg plate adapter cable (M1362B).

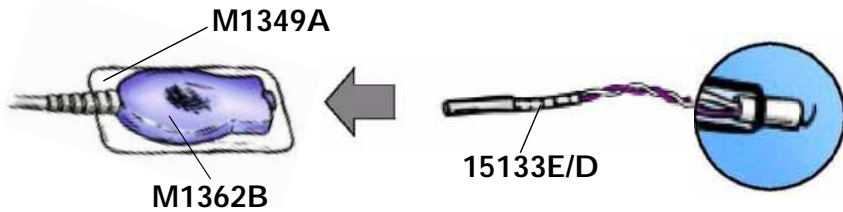

6. Peel the backing from the electrode (M1349A) and affix it to the mother's thigh. A good contact between the electrode and the mother's skin will improve the FHR signal. To get the best signal, ensure that the skin is clean and dry before attaching the electrode. Ensure that the electrode is correctly positioned to prevent tension in the cable from pulling on the Fetal Scalp Electrode and injuring the fetus.
7. You are now ready to begin monitoring DECG: see the section "Monitoring DECG" for your next step.

## With Patient Module M1364A

To monitor fetal DECG using the DECG leg plate adapter cable M1362B and an ECG-only patient module (M1364A), follow these instructions.

1. Attach a pre-gelled electrode (M1349A) to the DECG leg plate adapter cable (M1362B).

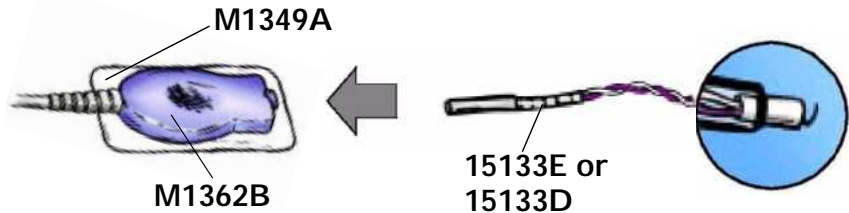

2. Connect the Fetal Scalp Electrode (15133E/15133D) to the DECG leg plate adapter cable (M1362B).
3. Peel the backing from the electrode (M1349A) and affix it to the mother's thigh. A good contact between the electrode and the mother's skin will improve the FHR signal. To get the best signal, ensure that the skin is clean and dry before attaching the electrode. Ensure that the electrode is correctly positioned to prevent tension in the cable from pulling on the Fetal Scalp Electrode and injuring the fetus.

4. Attach the pink connector (1) on the DECG leg plate adapter cable (M1362B) to the ECG pink connector (1) on the patient module (M1364A).

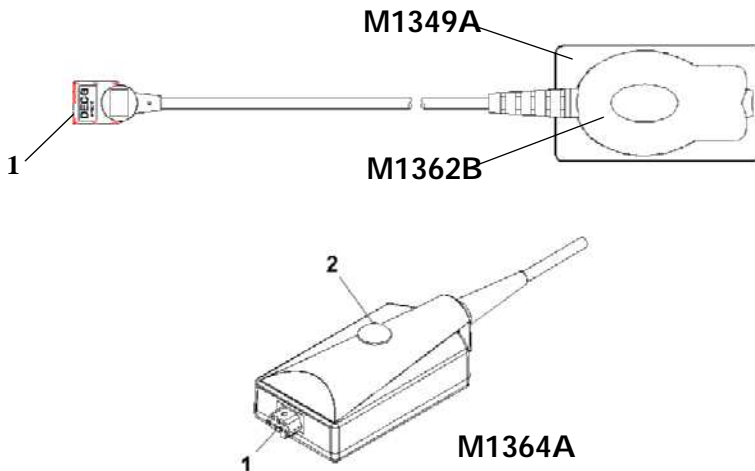

5. Fix the patient module to the patient's belt using the fixing knob (2).
6. You are now ready to begin monitoring DECG: see the section "Monitoring DECG" for your next step.

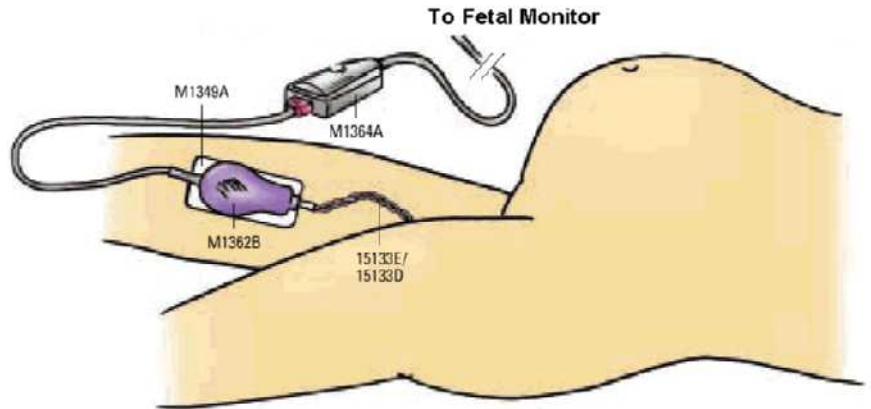

Typical Configuration Showing Fetal Scalp Electrode 15133E/D, DECG Adapter Cable M1362B, and Patient Module M1364A

---

## Monitoring DECG

1. Switch on the monitor and the recorder **(1)**.
2. Connect the legplate or patient module to the US2/ECG socket on the monitor **(2)**.

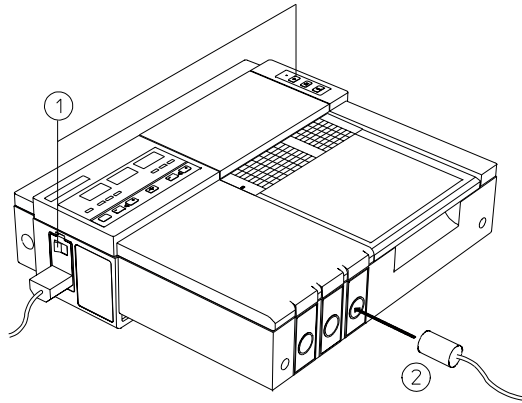

3. Check the arrhythmia logic setting.

---

### Warning

**During monitoring, periodically compare the mother's pulse with the signal coming from the monitor's loudspeaker to ensure that you are monitoring fetal heart rate. Do not mistake a high maternal heart rate for FHR. With the Series 50 IP-2, use cross-channel verification alerting if possible, to warn you if maternal and fetal heart rates coincide.**

---

### Switching Arrhythmia Logic On and Off

Before you can switch arrhythmia logic off and on, a DECG transducer must be connected to the ECG socket.

You can change the setting by pressing **F.▲** until the monitor displays **LOG**.

Use **+** and **-** to turn arrhythmia on and off.

A red signal quality indicator indicates logic is OFF. Green indicates logic is ON.

### Why use Arrhythmia Logic?

When arrhythmia logic is on, instantaneous heart rate changes of  $\pm 28$  bpm or more are not recorded. Recording resumes when successive beats again fall within predetermined limits. This avoids recording artifacts but does not show genuine arrhythmia.

When logic is off, **DECG (no LOG)** is printed on the trace paper and all recorded fetal heartbeats are shown. If you suspect fetal arrhythmia, switch logic off. Unless you suspect fetal arrhythmia, we recommend that you use the default setting, with logic on to suppress artifacts, as this makes the trace easier to read and interpret.

**Note—If you switch arrhythmia logic off while monitoring, be sure to switch it on again afterwards.**

---

## Removing the Fetal Scalp Electrode

The Fetal Scalp Electrode can be removed with the presenting part crowning and the application site visible, or after delivery. Turn the electrode in a counter-clockwise direction to remove it. Never pull it off or reuse it.

## Troubleshooting

Problem	Possible Causes	Solutions
Erratic trace. Erratic display.	No ECG signal Poor contact between the reference electrode and the mother.	Use a new Fetal Scalp Electrode.
Erratic trace.	Patient module or transducer is not securely fixed.	Affix the patient module to the patient's belt with the fixing button. Secure the DECG leg plate adapter cable with a pre-gelled electrode.
Signal quality indicator is red continuously.	Fetal arrhythmia.	Be sure that logic is off.
<b>nop</b> displayed.	Electrode leads not properly connected to cable block.	Check electrode lead connection.
	No contact or poor contact between reference electrode and mother.	Use a new Fetal Scalp Electrode.
	Fetal Scalp Electrode detached.	Reattach the Fetal Scalp Electrode.
An error message is displayed.		See Chapter 15, "Troubleshooting."
If you suspect the signal from the transducer.		Carry out the Parameter Test as described on page 115.
If you suspect the recorder or display.		Carry out the Quick Test as described on page 114.







# Monitoring Twin FHRs

---

## Introduction

### *Series 50 A Only*

Using the Series 50 A fetal monitor, Dual Ultrasound model, you can monitor twin FHRs externally using two ultrasound transducers. It is not possible to monitor twin FHRs using the Single Ultrasound model.

### *Series 50 IP-2 Only*

Using the Series 50 IP-2 fetal monitor you can monitor twin FHRs throughout labor and delivery after rupture of the membranes by monitoring one twin externally using ultrasound and the other internally using DECG. You can monitor twin FHRs externally using two ultrasound transducers. (External FHR monitoring using the second ultrasound channel is possible also before the rupture of the membranes).

Refer to the appropriate preceding chapters for contra-indications and other information about the measurement methods you have chosen.

---

## Things to Remember During Monitoring

When monitoring you should:

- Make sure that you are recording two different heart rates. The cross-channel verification feature alerts you if the two heart rates coincide (that is, if both transducers are recording the same FHR). If this happens, reposition an ultrasound transducer until you detect the second FHR.

- Note that the trace recorded for the US/US1 channel is thicker (darker) than that recorded for the US2/ECG channel. This ensures that the two heart rates are easily distinguishable.
- Remember that only one fetal heartbeat can be heard from the loudspeaker at any time. You can identify which fetus you are listening to by seeing which speaker light is on. To hear the other fetal heartbeat, press either of the volume keys for the channel monitoring that fetus.
- Monitor maternal pulse, especially during later stages of labor, to avoid mistaking maternal heart rate for FHR.
- Make sure you're recording the best possible signals by referring to the signal quality indicators and repositioning the transducers if necessary.

---

## Monitoring Internally

*Series 50 IP-2  
Only*

Monitor one twin using the procedures described in Chapter 4, "Monitoring FHR and FMP Using Ultrasound." Monitor the second twin using the procedures described in Chapter 5, "Monitoring FHR Using DECG."

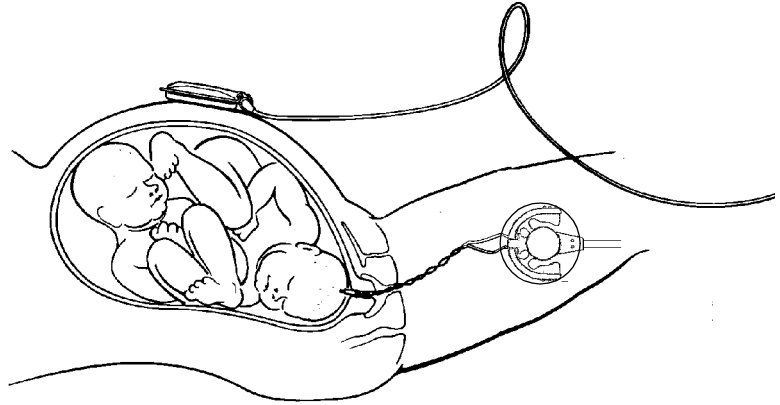

Monitoring Twin FHRs Using the Series 50 IP-2

---

## Monitoring Externally

### *Series 50 A and Series 50 IP-2*

To monitor twin FHRs externally you will need the Series 50 A Dual Ultrasound or the Series 50 IP-2 fetal monitor and two ultrasound transducers. Follow the procedures described in Chapter 4, “Monitoring FHR and FMP Using Ultrasound.” Removing the white clips from both ends of one transducer will help you to distinguish at a glance the US1 transducer from the US2/ECG transducer.

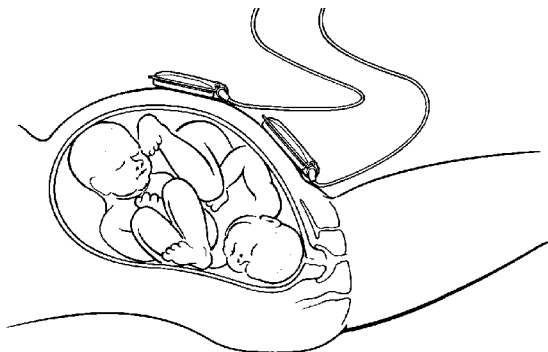

**Monitoring Twin FHRs Externally Using Two  
Ultrasound Transducers**

Refer to “Troubleshooting” on page 63 to identify problems specifically associated with monitoring twin FHRs.

---

## Cross-Channel Verification

If the two monitored heart rates coincide at any time (that is, if both transducers are recording the same FHR), this is detected via cross-channel verification and **?** is repeatedly printed on the trace paper after about 30 seconds. You should reposition one of the transducers to correctly detect the second FHR.

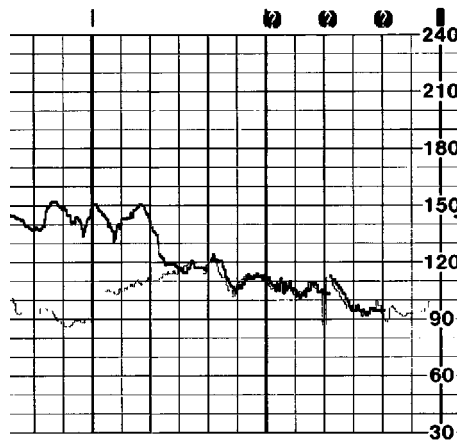

---

## Separating Twin FHR Traces: “Twins Offset”

To help you to interpret traces with similar baselines, you can separate the baselines, so that one is displayed on the trace as if it is 20 bpm higher than the other. Use either the function key or the optional barcode reader to separate the traces. This feature is also known as “Twins Offset.”

## Using Keys

1. Connect both fetal transducers to the monitor.

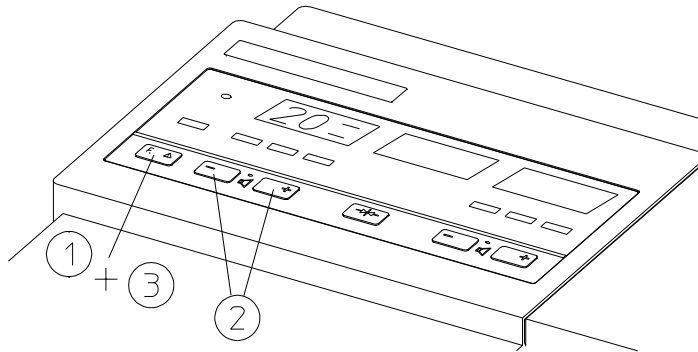

2. Press **F.A** and release to display **20**  
The Signal Quality Indicator shows:
  - RED if the traces are NOT SEPARATED.
  - GREEN if the traces are SEPARATED.
3. Press **-** or **+** to change the setting.
4. Press **F.A** several times to return to the normal display.  
You will also be returned to the normal display if you don't press any key for a number of seconds.

## Using the Barcode Reader

Enter “Twins Offset” from the barcode sheet.



## Twins Offset: On

After you have switched Twins Offset on:

The trace from the ultrasound transducer connected to the left (US1) socket is offset.

- A dotted line labeled '+20' prints across the FHR scale.
- The US trace is labeled '+20' every 5cm.

The following trace shows Twins Offset switched on.

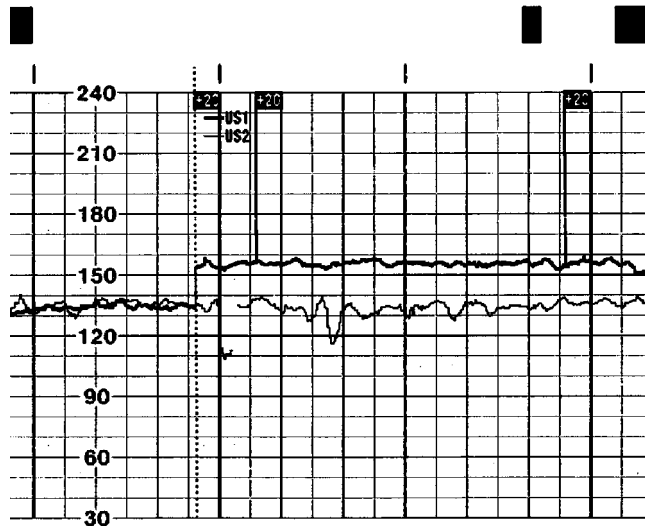

Only the US1 trace is offset. The numerical FHR value displayed on the monitor remains unchanged. The US2/ECG trace and display do not change. Subtract 20 from the US1 recorded trace to calculate the true FHR. For example, if the recorded trace shows 160 then the true FHR is 140.

If you disconnect the ECG/US2 transducer, the US1 trace returns to normal. But if you later reconnect the ECG/US2 transducer, the US1 trace is automatically offset again.

### Twins Offset: Off

To indicate that twins offset is switched off a dotted line labeled "+0" prints across the FHR scale.

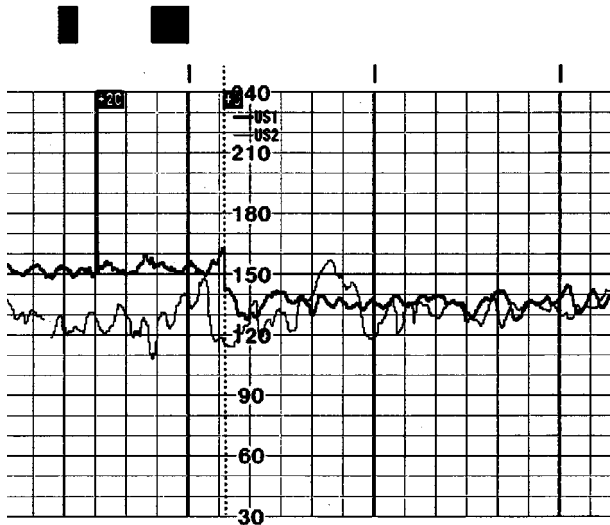

Switching off the monitor automatically switches off twins offset.

## Troubleshooting

Common problems that may occur when monitoring FHR using ultrasound are listed in Chapter 4, “Monitoring FHR and FMP Using Ultrasound.” See also Chapter 5, “Monitoring FHR Using DECG,” for common problems you might encounter when monitoring FHR directly.

The following problem may occur when monitoring twins.

Problem	Possible Cause	Solution
<p> is printed repeatedly</p>	<p>Both transducers are recording the same FHR</p>	<p>Reposition an ultrasound transducer</p>
<p><b>Series 50 IP-2 only</b> When a transducer is plugged into/unplugged from the US2/ECG socket, and a transducer is also connected to the US1 socket there will be a temporary loss of signal (typically less than three seconds) on the US1 channel. The signal indicator will turn red for a short time.</p>	<p>Re-boot of the signal processor software. This is a normal system characteristic, and does not indicate a malfunction.</p>	<p>No action needed.</p>



# Monitoring Uterine Activity

---

## Introduction

Uterine activity can be measured externally using a Toco transducer, or internally using an intrauterine catheter. A Toco transducer is a pressure-sensitive device that measures the frequency and the duration of contractions but not their intensity. Amplitude and sensitivity are affected by various factors such as the position of the transducer, the belt tension, and the size of the patient. To obtain an absolute measurement, you must monitor uterine pressure directly.

Monitor the mother for about 30 minutes. If she changes position or moves onto her side at any time, remember to press the toco baseline key to readjust the baseline.

### *Series 50 A and Series 50 IP-2*

With the Series 50 A fetal monitor and the Series 50 IP-2 fetal monitor you can monitor uterine activity externally using a Toco transducer.

### *Series 50 IP-2 Only*

Using an intrauterine catheter you can monitor intrauterine pressure internally with the Series 50 IP-2 fetal monitor. This parameter can only be used after the membranes have ruptured and the cervix is sufficiently dilated.

---

## What You Need

### For External Monitoring

- Toco transducer
- Transducer belt and button.

## For Internal Monitoring

If you are using a re-usable transducer:

- Transducer
- Holder
- Disposable intrauterine kit
- Dome, if this is not included in the kit
- Sterile water or saline solution.

If you are using a disposable IUP kit:

- Disposable intrauterine catheter
- Transducer adapter cable.

---

## External Toco Monitoring

1. Fasten the abdominal transducer belt around the patient.
2. Switch on the monitor and the recorder.
3. Connect the Toco transducer to the Toco socket on the monitor (1).

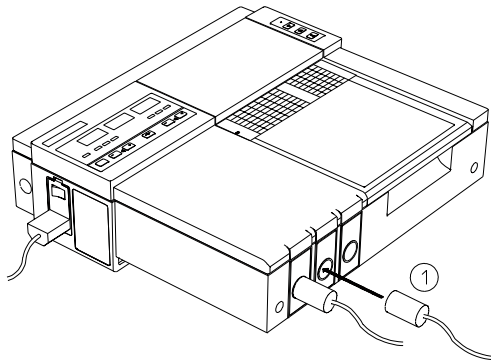

4. The Toco display shows 20.  
“Toco ext”, indicating external uterine measurement, is printed on the trace intermittently.

5. Place the transducer on the patient's fundus to ensure the optimum recording of uterine activity.
6. When you have a good signal, clip the transducer in position on the belt.
7. Between contractions, press the toco baseline key. This zeroes the display and trace to 20.

The following example trace shows two contractions.

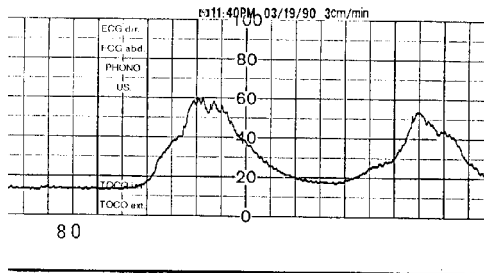

## Internal Toco Monitoring (IUP Monitoring)

### *Series 50 IP-2 Only*

You can monitor intrauterine pressure (IUP) using either a reusable or a disposable intrauterine catheter. Each catheter comes with its own detailed user instructions. Read the instructions that come with your intrauterine catheter before you start monitoring. Ensure that you zero the monitor when instructed.

Perform a complete clinical evaluation. Catheterize after membrane rupture. Do not catheterize if placenta previa is diagnosed or if uterine bleeding from an undetermined source is present.

1. Insert the catheter according to its accompanying instructions.
2. Connect the catheter to the monitor's Toco socket. Some catheters link to a cable that connects to the monitor. The Toco display shows 0.

“Toco int”, indicating internal measurement, is printed intermittently on the trace.

3. Zero the monitor by pressing the toco baseline key . This zeroes the display and trace to 0. If you do not zero the monitor properly, the pressure trace may exceed the paper scaling. To correct this, ensure that the transducer is level with the lower end of the mother’s sternum (xiphoid), then zero the monitor.
4. Flush periodically during monitoring. A pressure spike appears on the trace if you flush after connecting the transducer to the monitor.

## Troubleshooting

### External Toco

Problem	Possible Causes	Solutions
Quality of the trace deteriorates or the Toco baseline varies	The belt is incorrectly fastened and is too slack or too tight or the belt has lost its elasticity	The belt must be tight enough to ensure good contact between the patient’s skin and the entire surface of the transducer without causing discomfort. Ensure you are using the correct Philips belt. Adjust it as necessary.
	Maternal movement	Relax the patient
	Fetal movement	None
	Maternal respiration superimposed on trace	Check belt is not too loose
Toco sensitivity is too high (above 100 units)	Physical transmission of pressure from the uterus to the sensor is much higher than the average value	Ensure a good contact between the patient’s skin and the entire surface of the transducer. Reposition transducer if necessary.



<b>Problem</b>	<b>Possible Causes</b>	<b>Solutions</b>
An error message is displayed		See Chapter 15, “Troubleshooting” for a list of error messages
If you suspect the signal from the transducer		Carry out the Parameter Test as described on page 115.
If you suspect the recorder or display		Carry out the Quick Test as described on page 114.

### Internal Toco

<b>Problem</b>	<b>Possible Causes</b>	<b>Solutions</b>
No trace	Catheter blocked	Flush with sterile solution
No change in pressure during contraction	Dry environment or possible extra-ovular placement of sensor tip	Flush with sterile solution or reposition sensor
Only pressure peaks can be seen (baseline not visible)	Zero adjustment is incorrect	Zero the system
“-” indicator flashes		
Trace is a straight line	Transducer is defective	Remove and touch the catheter. If the trace does not show up and down movements, use a new transducer.
Trace is superimposed with noise	End of catheter is in the uterine wall or dry column	Retract the catheter a little and flush
An error message is displayed		See Chapter 15, “Troubleshooting” for a list of error messages

Problem	Possible Causes	Solutions
	If you suspect the signal from the transducer	Carry out the Parameter Test as described on page 115.
	If you suspect the recorder or display	Carry out the Quick Test as described on page 114.

# Measurements Using External Devices

---

## Introduction

### *Series 50 A and Series 50 IP-2*

You can extend the range of measurements your fetal monitor can carry out by connecting external devices to it. To do this, your monitor must have a combined interface module and it must be correctly configured for the option.

In this chapter you will learn how to:

- Connect external supported devices to your fetal monitor
- Record maternal non-invasive blood pressure (NIBP)
- Monitor the fetal blood oxygen saturation level (FSpO<sub>2</sub>).

---

## Supported External Devices

The following table shows you which devices are supported and which accessories you will need to record using external devices.

Parameter	External Device	Accessories	Option
Maternal NIBP	Dinamap™ 1846/8100 NIBP Monitor	Interface cable M1350-61609; Combined Interface Module	J13
	COLIN Press-Mate™ / Nippon Colin Listmini Model BP-8800	Interface Cable (from COLIN); Combined Interface Module	J13
Fetal SpO <sub>2</sub>	Nellcor OxiFirst™ Fetal Oxygen Saturation Monitor (N-400)	Combined Interface Module; Interface Cable M1353-61614	J14

**Note—A model 8801 adapter is required from General Electric before the Dinamap™ can be installed.**

## Connecting External Devices to the Monitor

The external monitoring devices are connected to the Series 50 A and Series 50 IP-2 fetal monitors via the combined interface module which is located underneath the fetal monitor.

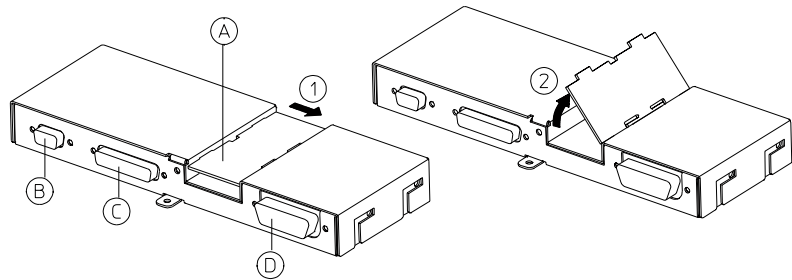

---

### Caution

**Before connecting an external device to the monitor, connect the equipotential grounding point to earth potential.**

---

To connect the external devices:

1. Push the plastic clamp in the direction indicated by the arrow (1) and lift out the plastic cable cover (A).
2. Use the interface cable to connect the external device to the sockets on the interface module:
  - Socket B: connect either a maternal NIBP monitor or a fetal oxygen saturation monitor or a barcode reader
  - Socket C: connect a fetal ultrasound telemetry system
  - Socket D: connect an Philips obstetrical surveillance system such as OB TraceVue
3. Connect the other end of the interface cable to the external monitor. See the Service Documentation supplied with the external device for the correct socket to use for the connection.
4. Tighten the screws on the connectors.

5. Feed the cable through the hollow in the center of the interface module and then push the cable clamp into place.  
If you are fitting the monitor to the wall you may also feed the power cable through the hollow in the center of the interface module.

See Chapter 15, “Troubleshooting,” for instructions on how to test a barcode reader. Refer to the Service and Installation Guide for your monitor for details of the interface between the fetal monitor and the OBMS, ODIS, OB TraceVue, and the telemetry system, and for instructions on how to configure the monitor when connecting a barcode reader, maternal NIBP recorder or FSpO<sub>2</sub> monitor.

## Trace Display on Obstetrical Surveillance Systems

The trace displayed on a connected monitoring system may not be identical to the recorder trace. The following details may not be shown on the system:

- Notes annotated on the paper using the barcode reader
- Fetal movement profile
- Separated twin FHR traces (when the US1 trace is offset by 20 bpm)
- FSpO<sub>2</sub>
- Maternal parameters.

Refer to the system specifications of the individual external devices for detailed information on which parameters are transmitted to the fetal monitor trace.

---

## Monitoring Maternal NIBP

### *Series 50 A and Series 50 IP-2*

To monitor maternal NIBP using either the Series 50 A or the Series 50 IP-2 fetal monitors, connect a supported NIBP monitor to your fetal monitor.

If you are using automatic mode with a short repetition interval, not all measurements can be recorded on the trace. The speed at which the paper moves through the recorder determines when measurements are printed.

Paper Speed	Measurement Notation
1 cm/min	Every 3 minutes
2 cm/min	Every 2 minutes
3 cm/min	Every 1 minute

## Example Maternal NIBP Trace

Each time the NIBP monitor takes the maternal NIBP measurement, it is printed on the trace. If you are only monitoring maternal NIBP, an MHR measurement is printed at the same time as the NIBP measurement.

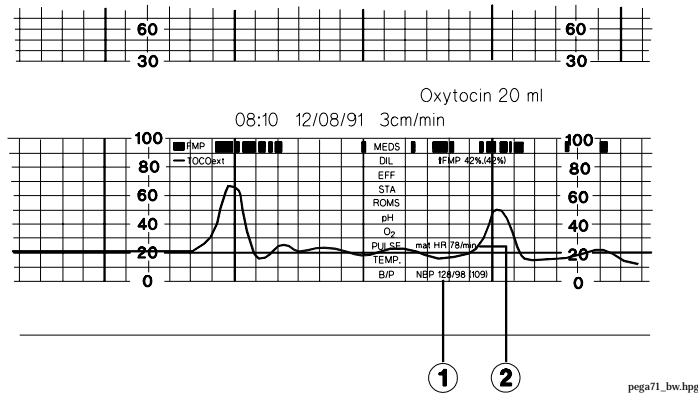

### Trace statistics

1. Blood pressure:
  - Systolic blood pressure is 128 mmHg
  - Diastolic pressure is 98 mmHg
  - Mean arterial pressure is 109 mmHg.
2. Maternal Heart Rate is 78 bpm.



## Monitoring FSpO<sub>2</sub>

### Introduction

Fetal pulse oximetry (FSpO<sub>2</sub>) gives you a continuous real-time measurement of the percentage of oxygen saturation in the fetal arterial blood. Identifying adequately oxygenated fetuses and those at risk of hypoxia may help clarify whether or not intervention in the case of a non-reassuring fetal heart rate trace is necessary.

To monitor FSpO<sub>2</sub> using either the Series 50 A or the Series 50 IP-2 fetal monitor, connect a supported FSpO<sub>2</sub> monitor to your fetal monitor. See the Service Documentation supplied with the FSpO<sub>2</sub> monitor for the correct DIP switch and baudrate settings for the FSpO<sub>2</sub> monitor.

### Example FSpO<sub>2</sub> Trace

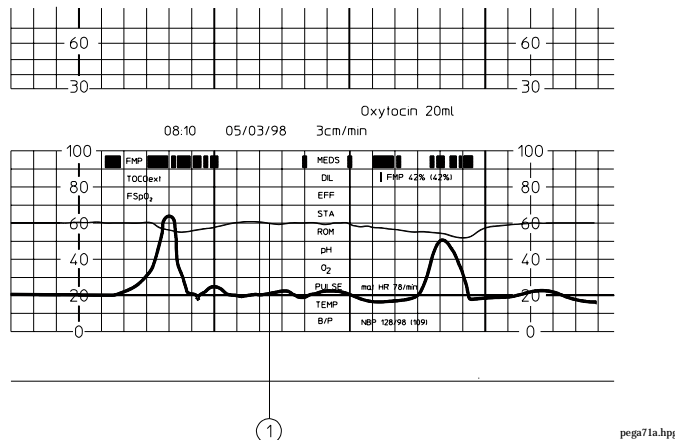

The FSpO<sub>2</sub> measurement is printed on the trace (1). Typical fetal oxygen saturation values are in the range 30% to 60%. Oxygen saturation greater than 80% and/or pulse rate less than 100 could indicate that the values are maternal in origin. Check the sensor to ensure that it is correctly positioned on the fetus.

---

## Troubleshooting

### FSpO<sub>2</sub>

If the external Nellcor OxiFirst™ FSpO<sub>2</sub> monitor (N-400) has two power switches (a mains switch at the rear of the unit and a standby switch at the front of the unit), take care to switch them on and off in the correct order, as shown below. If you do not, the unit can appear to malfunction by displaying data erratically, or not at all.

- To switch off the N-400
  - Turn the front switch (on/standby) to standby
  - Turn the rear switch (mains power switch) to off.
  
- To switch on the N-400
  - Turn the rear switch (mains power switch) to on
  - Turn the front switch (on/standby) to on.

If the unit malfunctions, switch it off as described above, wait for five seconds and then switch it on again.

If you use the N-400 regularly, we recommend that you keep the rear switch (mains power) in the “on” position and use the front switch (on/standby) to change from on to standby mode.

### External Devices

The following table identifies common problems you may encounter when recording using external monitoring devices. See the Service and Installation Guide for your monitor for more information on how to configure the fetal monitor before connecting external devices.

Problem	Possible	Solution
<b>General - All External Devices</b>		
No measurements are printed on the trace	Cable connected incorrectly	Check cable connections
	External device is not configured to the fetal monitor	Check configuration settings on the external device. See external device service guide for details
	Combined Interface Module is not configured to the external device	Check Interface Board settings. See the Service and Installation Guide for your monitor for more information on how to configure the fetal monitor before connecting external devices
	Combined Interface Module is not working	Carry out the Self Test as described on page 113 and see the list of error messages in Chapter 15, "Troubleshooting"
An error message is displayed		See Chapter 15, "Troubleshooting," for a table of error messages, their causes and solutions
You suspect the signal from the transducer may be misleading		Carry out the Parameter test as described on page 115
You suspect the recorder or the display may be misleading		Carry out the quick test as described in Chapter 15, "Troubleshooting" on page 113
The maternal NIBP measurement is not complete and the NIBP monitor is in automatic mode	The time interval between each measurement is too short	Set minimum time interval according to paper speed

Problem	Possible	Solution
<b>Nellcor OxiFirst™ Fetal Oxygen Saturation Monitor (N-400)</b>		
No FSpO <sub>2</sub> measurements are printed on the trace	Nellcor monitor is being powered by its internal battery. (Battery power symbol is lit.)	Switch on AC power as described in the section on FSpO <sub>2</sub> troubleshooting above. When you do this, the battery power symbol should go out.
	FSpO <sub>2</sub> monitor is not configured to the fetal monitor	Set DIP switches and baudrate on FSpO <sub>2</sub> monitor correctly
	Fetal monitor is not configured to the N-400	Ensure service setting key C10 is set to 3. See the Service and Installation Guide for your monitor for more information.

# Monitoring Maternal ECG

---

## Introduction

### *Series 50 IP-2 Only*

Using the Series 50 IP-2 fetal monitor and an MECCG transducer or patient module you can monitor maternal ECG. The maternal heart rate is printed on the trace and you can hear the heartbeat from the monitor's loudspeaker, but it is not shown on the display or on the signal quality indicator.

In this chapter you will learn how to:

- Apply the electrodes to the mother
- Monitor MECCG using a transducer or a patient module
- Avoid mistaking maternal heart rate for fetal heart rate
- Solve common problems which can arise while monitoring MECCG.

---

## Monitoring Maternal ECG

### *Series 50 IP-2 Only*

You will need:

- MECCG transducer or patient module
- Two MECCG electrodes
- Two electrode leads

---

## To Begin Monitoring

1. Connect the transducer or patient module to the ECG socket on the fetal monitor.
2. Connect the pre-gelled electrodes to the transducer or to the patient module:

### Using MECG Transducer M1359A

- If you are using an MECG transducer, connect each electrode lead to an electrode and to the transducer.

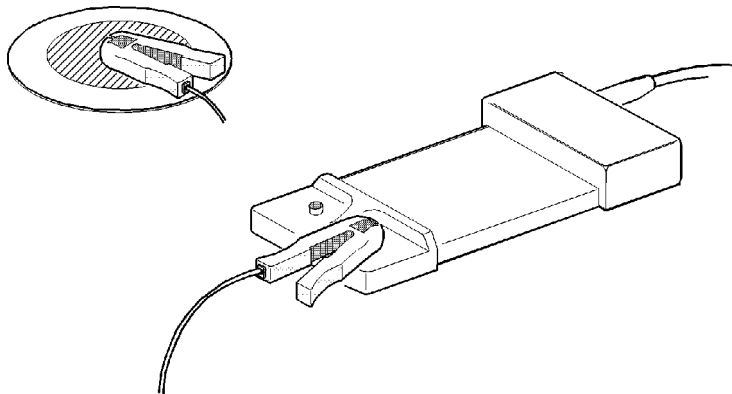

### Using a Patient Module M1364A

- If you are using a patient module and an adapter cable M1363A to monitor MECG, connect each lead to a pre-gelled electrode (4).

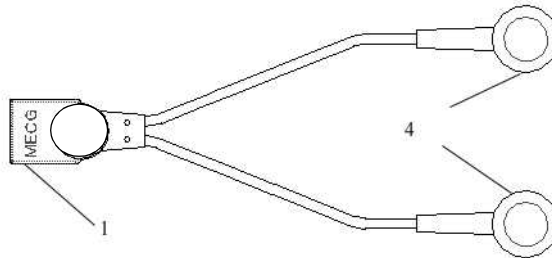

Connect the pink connector **(1)** on the MEEG adapter cable to the ECG connector **(1)** on the patient module.

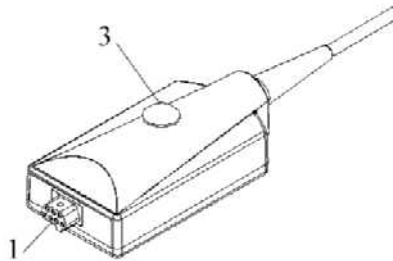

3. Peel the backing from the electrodes and apply them to the patient.

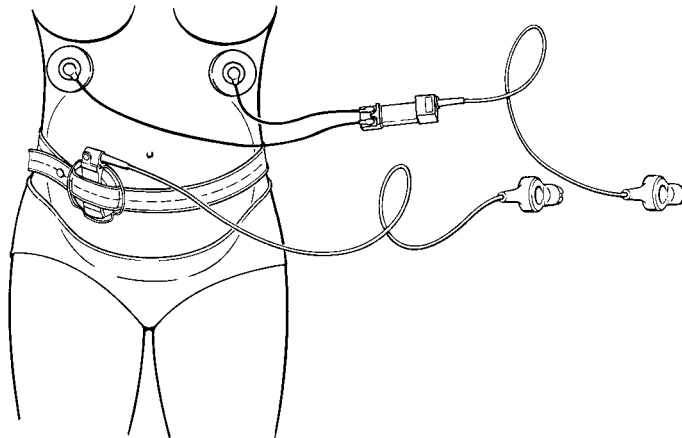

The loudspeaker emits a click when a heart rate is being monitored. The click volume is controlled via the service setting. The MHR trace (which is thinner than a fetal trace) prints on the paper. There is no signal quality indicator for MEEG.

4. Slide the transducer or patient module under the belt or clip the cable to the bed sheet or patient's clothing.

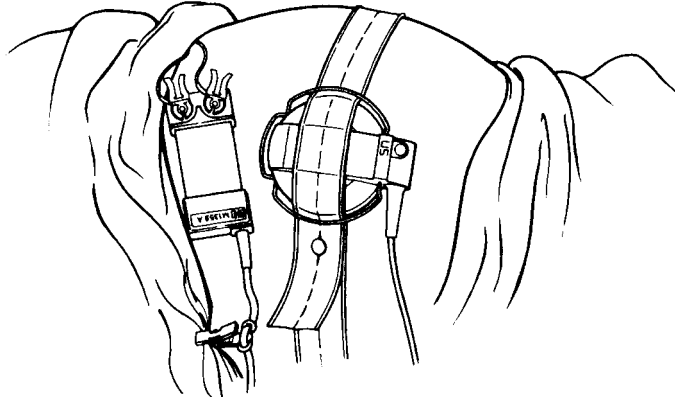

### Cross-Channel Verification

To reduce the possibility of mistaking maternal heart rate for fetal heart rate (FHR) we recommend that you monitor both maternal and fetal heart rates, especially during the later stages of labor. If FHR and MHR coincide (that is, if the ultrasound transducer records MHR instead of FHR), the monitor's cross channel verification facility detects this and prints **?** on the paper after 30 seconds.



## Troubleshooting

This section details problems that might occur when measuring maternal ECG.

Situation	Possible Cause	Possible Solution
Monitor displays NOP .	Electrodes defective. Bad electrical contact.	Check electrodes and replace if necessary. Check positioning of electrodes.
 prints repeatedly.	The ultrasound transducer is recording MHR.	Reposition the ultrasound transducer.
An error message is displayed.		Refer to the table of error messages and solutions in Chapter 15, “Troubleshooting.”
If you suspect the signal from the transducer.		Carry out the Parameter Test as described on page 115.
If you suspect the recorder or display.		Carry out the Quick Test as described on page 114.



# Fetal Heart Rate Alerting

---

## Introduction

Fetal heart rate alerting can give both audible and visual warning of a non-reassuring fetal condition. Fetal heart rate (FHR) alerting is **NOT** available for monitors purchased in the USA.

---

## Alerts

Your monitor must be enabled for alerting, via a service setting, before you can use the alert facilities. The default setting for FHR alerting is off.

## Recognizing an Alert

When the fetal heart rate is outside a given **High Alert Limit** (tachycardia) or **Low Alert Limit** (bradycardia) for a defined length of time (**Delay**), the monitor gives an audible alert and flashes the FHR numeric display.

FHR alerting activates after about half a minute of valid heart rate signals (green or yellow signal quality indicator). When the recorder has been switched off, the alerting is reset and another half minute of valid FHR is required to activate the alerting. This prevents the monitor giving a signal loss alert when no patient is being monitored. The monitor treats signal loss as bradycardia.

## Acknowledging an Alert

Press the Mark key (ack.) to acknowledge an alert. If the FHR remains outside the given limits after you acknowledge an alert, the alert recurs after the delay time.

## Turning Alerting ON or OFF

1. Connect either
  - an ultrasound transducer to a US socket (if you are measuring FHR using ultrasound)
  - a DECG transducer to the ECG socket (if you are measuring FHR directly)
2. Press **F.▲** repeatedly until **AL** is displayed.  
The Signal Quality Indicator shows:
  - RED if fetal alerting is OFF.
  - GREEN if fetal alerting is ON.Press **-** or **+** to change this setting.

## Changing Alert Limits

The settings for the High Alert Limit, Low Alert Limit, and the Delay before the alert is given, are adjustable.

1. Connect either
  - an ultrasound transducer to a US socket (if you are measuring FHR using ultrasound)
  - a DECG transducer to the ECG socket (if you are measuring FHR directly)

2. Press **F.▲** repeatedly until **AL** is displayed.  
 To display the value to be changed, press the TOCO adjust key **←→** or the recorder marker key.  
 Use **-** and **+** to set a new alert setting.

Alert Setting (shown in FHR1 display)	Alert Setting (shown in Toco display)
High alert limit Default 150 bpm, 0 = off	--A
Alert delay for high limit Default 60 seconds	"-A
Low alert limit Default 110 bpm, 0 = off	--A
Alert delay for low limit Default 60 seconds	"_A

The monitor memorizes these settings and stores them, even when switched off. They are printed on the trace paper every few pages if alerting is on.

3. Press **F.▲** to return to the normal display or wait 15 seconds for the data to be automatically entered.



# Non Stress Test Timer



---

## Introduction

This chapter explains how to set the non stress test (NST) timer.

---

## Setting the NST Timer

1. Ensure the recorder is off.
2. Press the recorder ON/OFF key  for 2 seconds.
3. Adjust the timer using the  and  keys. The setting is displayed for 15 seconds and the timer starts. An egg timer symbol is printed on the paper to indicate that the NST timer is activated.

To switch the timer off, select a setting of 0.

After the selected time has passed:

1. A 10 second audible tone sounds (optional).
2. The recorder stops (optional).
3. The paper advances to the next perforation.

Optional settings for the NST timer are enabled via a service setting and are listed in the Installation and Service Guide for your monitor.

## Setting the NST Timer



# 12

## Recording Notes

---

### Introduction

The optional barcode reader and sheets of barcodes let you record your most commonly-used notes, and some patient information on the trace.

---

### Recording A Note

To record a note on the trace:

1. Switch on the recorder.
2. Hold the reader pen as you would a normal pen.
3. Place the tip of the pen in the white margin on one side of the barcode.
4. Using gentle pressure and constant speed, draw the pen (from right to left, or left to right) over the center of the barcode to the white margin on the other side. Do not let the pen wander from the barcode or stop before it reaches the white margin

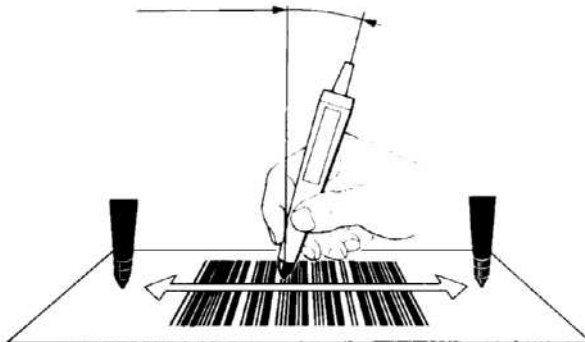

The monitor “beeps” when it receives the barcode. If there is no “beep”, you should read the barcode again.

---

## Deleting a Barcode Note

Read “CANCEL” to delete an entry. If you do not read “CANCEL” within 15 seconds, the note is entered automatically.

---

## Recording a Patient’s Name

To record a patient’s name on the paper:

1. Read each letter of the patient’s first name.
2. Read “SPACE”.
3. Read each letter of the patient’s second name.
4. Read “ENTER”.

---

## Recording Several Barcodes as One Note

To record several barcodes as one note, read each barcode in turn and then read “ENTER”. The maximum length of a note is 30 characters. The note is printed on one line.

For example, to record a blood pressure of 150/85 as shown in the picture below:

1. Read the following codes:  
BP:  
1  
5  
0  
/  
8  
5
2. Read “ENTER”.



## Recording Several Barcodes as Separate Notes

# Modem Interface Module

---

## Introduction

*Series 50 A  
Only*

The modem interface module, used with an approved PCMCIA modem, lets you send fetal trace information from a Series 50 A fetal monitor to an OB TraceVue receiver that has an appropriate modem and software. You can send information over a standard telephone line. The receiver software displays the trace information and lets the receiver review, print, and store it.

---

### Caution

**This device is not intended for unsupervised use by a patient. It must be used under the supervision of a clinical professional.**

---

---

## Connecting the Modem Interface Module

1. Remove the cover from the interface socket (or any other interface module) situated on the underside of the monitor.

2. Connect the modem interface module to the interface socket.

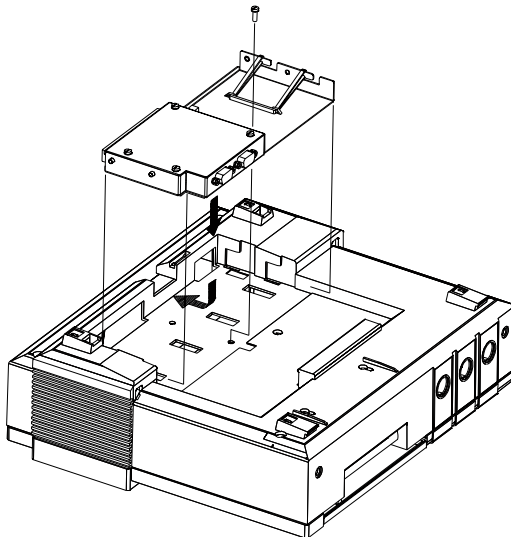

3. When the module is fitted, secure it in position by fixing it to the base of the monitor with the screw provided.

---

## Connecting Peripheral Devices

After you have fitted the modem interface module, you should connect the peripheral devices in the following order:

1. Connect the barcode reader to the module's RS232 interface socket **(1)**.  
Make the connection secure by tightening the screws on the connector.
2. Checking it is the correct way up, insert an Philips-approved PCMCIA modem into the card connector socket **(3)**, pushing it until it is slotted into position.

Socket two **(2)** is an auxiliary serial interface and it is intended for service purposes only.

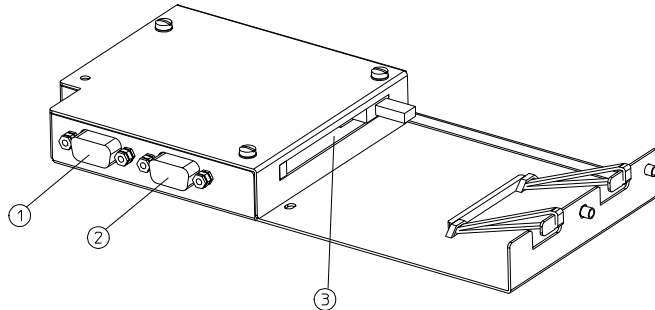

---

## Connecting to the Telephone System

Telephone wall jack connections differ from one country to another. If information is required to determine the appropriate telephone jack needed to connect the PCMCIA modem to the telephone network of a particular country, consult your local telephone company or site service engineer and follow the PCMCIA modem supplier's recommendation. Additional information about types of connections is given in the Service and Installation Guide for your monitor.

---

### **Warning**

**To avoid possible electrical hazards:**

**Whenever a patient is connected to the fetal monitor the cable to the telephone system must be disconnected.**

**Never touch open contacts on the cable which is connected to the telephone system.**

---

---

## PCMCIA Modem

The modem interface module accepts only a PCMCIA modem. Follow the manufacturer's and the telephone company's recommendations on fitting the modem.

An **Err 70** message with an audible alert (beep, beep, beep) is given if

- The modem is defective
- The modem is not installed or is installed incorrectly
- The modem is not compatible (not a model approved by Philips).

Philips does not supply this modem. If your modem is faulty, please contact the card's suppliers.

The modem used must conform to local regulations requirements and the following standards

- EN55022 Class B / FCC Part 15 Class B
- EN41003
- EN60950 / UL 1950

Only modems approved by Philips for software compatibility may be used. Please contact your local Philips representative for information on approved suppliers.



---

## Entering and Storing

### Barcode Reader

You use your barcode reader to start storing and transmitting fetal trace information. See Chapter 12, “Recording Notes,” for instructions on using a barcode reader. With the barcode reader you can:

- Enter the receiver phone number
- Enter the patient phone number
- Enter the patient ID
- Clear stored fetal trace data
- Start storage of the patient’s fetal trace
- Display the amount of minutes of fetal trace data stored in the memory
- Transmit stored data
- Stop the storage and transmission of data.

### Getting Started

All the barcodes you need to transmit patient data are on the barcode sheet supplied with the modem interface module. The sheet has two sides:

- Patient Identification
- Entering Telephone Numbers

This sheet is not part of the Series 50 Fetal Monitors Nursing/Midwife Notes package.

**Receiver Phone Number.** You must enter a receiver phone number. This defines the destination (that is, the receiver location or client PC of the OB **TraceVue** system) of the fetal trace information transmitted via the modem.

If the receiver number doesn’t change, you only need to enter this information once.

**Patient Phone Number.** You do not have to enter a patient phone number, but we do highly recommend it. It aids you in the correct assignment of transmitted fetal data to the patient’s file. It also lets the receiver phone the patient’s location to provide or request information.

This information must be updated for each patient.

**Patient ID.** The patient ID helps you correctly assign the fetal data to a patient's file by giving each patient a unique (alphanumeric) identity code.

This information must be updated for each new patient.

When you have successfully entered this information, you can start to store and transmit fetal trace data.

## Setting Phone Numbers and Patient ID

To operate the remote monitoring facility you will first need to enter:

- Receiver phone number
  - Patient phone number
  - Patient ID.
1. Scan the appropriate barcode, either:
    - *Receiver Phone*
    - *Patient Phone or*
    - *Patient ID.*
  2. From the numeric barcode list, scan each of the numbers that form the receiver phone number, the patient's phone number, or the patient ID which you have defined.
  3. Then scan the *Enter* barcode to enter this information. If you do not scan *Enter* the information will be automatically stored after 15 seconds.

If you make a mistake while entering the information, scan *Cancel* to clear the data and start the process again from the beginning.

If the recorder is on before you start to enter the patient phone information, the information mode and the data you have entered are printed on the trace.

## Keeping Patient Data

If you use the monitor for the same patient, you will probably want to retain the patient identification data. This will save you having to input it each time you send a trace. You can do this after transmission or when you clear trace memory.

Scan *Keep Patient Data after Transmission* once to retain the following data

- *Receiver phone number*
- *Patient phone number*
- *Patient identification.*

Keep Patient Data becomes the default setting and remains so until you scan *Clear Patient Data after Transmission* once.

## Clearing Patient Data

If you use the same monitor with many different patients, you will probably need to clear patient identification data after each transmission.

Scan *Clear Patient Data after Transmission* once to erase

- *Patient identification*
- *Patient phone number.*

The monitor retains the receiver phone number. Clear Patient Data becomes the default setting until you change this by scanning *Keep Patient Data after Transmission*.

To change the receiver phone number, simply enter the new receiver phone number as described above in “Setting Phone Numbers and Patient ID.”

## Clearing Trace Memory

To prevent accidental erasure of data, the instruction to clear memory must be scanned twice. To clear all fetal trace data stored in the memory:

1. Scan the barcode *Clear Memory*. The amount of fetal trace stored in the memory will be displayed, represented in minutes.
2. Scan the barcode *Clear Memory* a second time. Any fetal trace data stored in the systems memory is cleared and 0 is displayed briefly, indicating that the memory is empty.

Note that the “clear memory” command will not clear the patient identification data unless Clear Patient Data after Transmission is your current default setting.

## Storing Fetal Trace Data

To record fetal trace data and store it in the system memory:

Scan the barcode *Start Storing*. 0 is displayed, indicating that the trace memory is empty. Then the displayed 0 clears and the normal transducer display is shown. Two flashing dots (three in the case of the Series 50 A Dual Ultrasound model) indicate that storage is now taking place. The decimal dots continue to flash until storage is stopped. Then the dots are displayed continuously to show that a trace is stored in the memory.

If you scan the barcode *Start Storing* when the memory is not empty, the fetal trace stored in the memory is briefly displayed. Since storage is already in operation, the Start Storing command is ignored.

## Displaying Memory

To see the amount of fetal trace stored in the system memory, scan the barcode *Display Memory*. The digital display will briefly show the amount of fetal trace (in minutes) stored in the memory.

Whenever the decimal dots are displayed, you can scan the barcode *Display Memory* to see the amount of trace data stored in the memory. This does not affect the storage or transmission process.

## Stopping Storage

Scan the *Stop Storing* barcode if you need to stop the storage of data. The process will be halted and the amount of fetal trace stored in the system memory will be displayed briefly.

---

## Transmitting Data

---

### Caution

**Make sure you remove all transducers from the patient before connecting the fetal monitor to the telephone wall jack**

---

### Trace Transmission

To transmit stored fetal data to the receiver station, scan the barcode *Transmit Data*. The amount of fetal trace data stored in the memory is displayed, represented in minutes, while transmission takes place.

When the modem has connected to the remote receiver station, the stored fetal trace is transmitted. The digital display will show a countdown in minutes of the amount of fetal trace stored in the memory. When it reaches 0, all the data has been transmitted.

If the transmission has completed successfully, a double tone sounds (beep, beep) and the display clears.

The trace is automatically erased from the fetal monitor after successful transmission.

- If *Transmit Data* is scanned and no fetal trace is stored in the memory, 0 is briefly displayed. Since there is no data stored, no transmission takes place.
- If *Transmit Data* is scanned while the fetal trace is being stored, data storage is stopped.

### Stopping Transmission

Scan the *Stop Storing* barcode if you need to stop the transmission of data. The process will be halted and the amount of fetal trace stored in the system memory will be displayed briefly.

---

## Troubleshooting and Error Messages

This section details problems unique to this option. See Chapter 15, “Troubleshooting,” for a more complete list of standard fetal monitoring error messages.

Fetal trace data is sent to the receiver in packages called data-blocks. If a package is received successfully, the next package is sent, and so on until all the data has been received successfully. If transmission is interrupted, scan the barcode *Transmit Data* to continue the transmission process. The system remembers the last package that was received successfully and continues with the next package.

### Error Message 77

If transmission problems occur, the fetal monitor automatically tries to resend the remaining trace. If the attempt fails and data transmission stops, you will see the error message **ERR77** and a triple beep will alert you to the error.

1. Acknowledge the error by scanning the barcode *Display Memory* or by pressing any key on your monitor.
2. Try to send the trace again. The error message **ERR 77** clears and two digital dots (three if your monitor is a Series 50 A Dual Ultrasound model) are displayed, indicating that fetal trace information is still in the memory.

If the problem persists, refer to the section on Troubleshooting and Error Messages below.

## Error Messages

Problem	Possible Cause	Solution
<p><b>ERR 70:</b> PCMCIA card modem not responding. This message is signalled by three tones.</p>	<p>Modem incorrectly installed/not an approved model</p>	<p>Check that the modem is a correctly installed and Philips-approved model</p>
<p><b>ERR 77:</b> Telephone transmission failed or incomplete. This message is signalled by three tones.</p>	<p>Telephone line busy</p>	<p>Wait a short time and try to transmit the data again</p>
	<p>Telephone line faulty or tone/pulse information missing</p>	<p>Make sure that the phone line is properly plugged into the socket and the correct receiver phone number is entered</p>
<p><b>ERR 532:</b> Interface board failed. This message is displayed for 10 seconds. It may prevent data from being transmitted and may generate <b>ERR 70</b> and <b>ERR 77</b> messages.</p>	<p>Defective interface board</p>	<p>Replace with a new interface board</p>
<p>Transmission begins smoothly but stops each time you try to send a trace</p>	<p>The serial number of the sending fetal monitor may not be configured correctly at the receiving OB <b>TraceVue</b> system</p>	<p>Check the configuration at the receiver site</p>

## Power Failure

In the event of power failure, the normal Series 50 A/IP-2 features apply. The following features apply specifically to this option:

- Fetal trace storage cannot be continued after a power failure. If the length of the stored trace recovered after a mains failure is not large enough, that is, if some data might have been lost, clear the memory and record a new fetal trace.
- If the transmission of fetal traces is interrupted by a mains failure, the stored minutes of trace can still be transmitted after the power has been re-established. The modem will automatically try to retransmit the trace.
- If the power supply fails and the internal batteries are flat, any fetal trace stored in the memory is lost. The loss of memory will also cause the loss of date/time details, Toco offset and the error log. When the power supply is re-established the real time clock will display 4.4.44 00:00 and you must reset it.



# 14

## Upgrade Key

---

### Introduction

This chapter tells you how to use an upgrade key to upgrade the software of the Philips Series 50 A and Series IP-2 fetal monitors.

---

### Upgrade Procedure

1. Disconnect all transducers (and telemetry) from the monitor.
2. Switch on the monitor.
3. Plug the upgrade key into the service socket (to the right of the recorder) on your monitor (if applicable, first remove the little plastic cap on the service socket).
  - The “start upgrade” tone sounds (two short beeps) when the upgrade begins.
  - After about 45 seconds the fetal monitor display should change to “-8-”.
  - Within 7 minutes, the display counts down to “-0-”

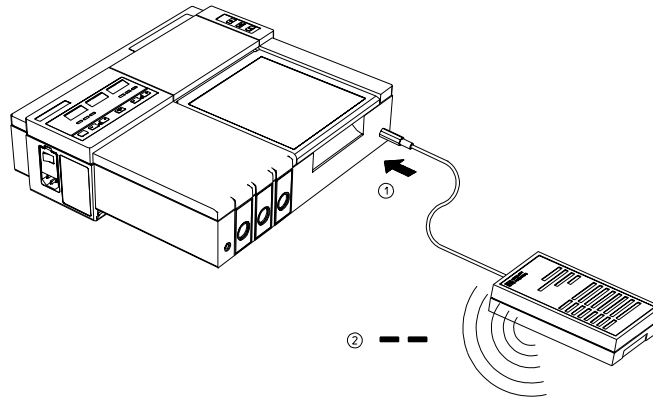

4. At the end of the procedure, you will hear the “upgrade successful” tone (a continuous beep lasting two seconds). The monitor display shows “-0-”. Unplug the upgrade key from the monitor.  
If you don’t hear the “start upgrade” tone or you hear the “upgrade failed” tone (a series of short beeps lasting 2 seconds), there may be several reasons:
  - The battery in the upgrade key may be low. Replace the battery.
  - You may already have carried out the maximum number of upgrades. The upgrade key is programmed to perform the number of upgrades ordered, to a maximum of 8.

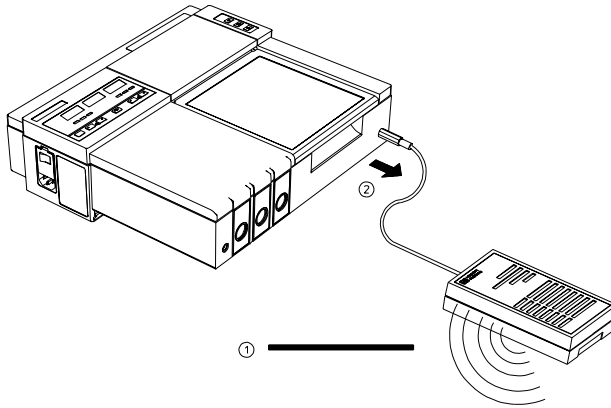

If you hear the upgrade failed tone, (a series of short beeps lasting 2 seconds), disconnect the upgrade key and try again from step 3 above.

If the upgrade still fails, carry out the quick test described in the Service and Installation Guide for your monitor. If the response is not the same as that described in the manual, contact Philips Support Service.

5. Write the serial number of the upgraded monitor in the space provided on the key. In this way you can keep a record of the monitors that have been upgraded.

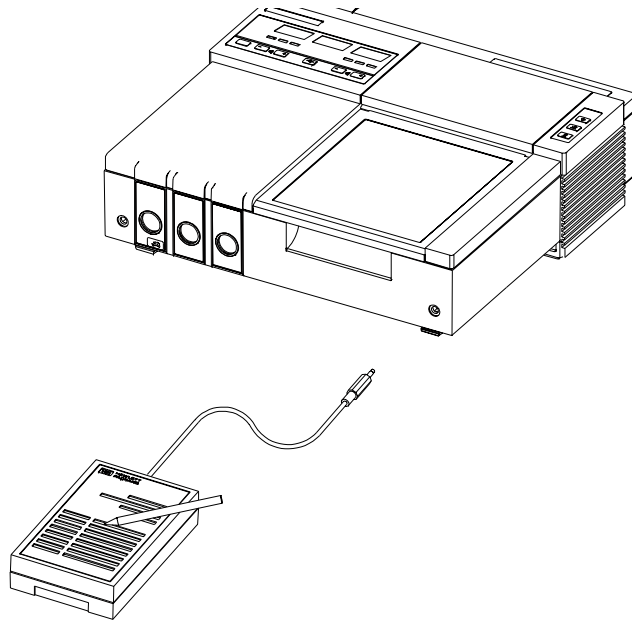

6. Switch the monitor off and then on: it will perform the power self-test. If an error message is displayed, contact Philips. If “-8-” is displayed, the upgrade was not successful. Try the upgrade again from the beginning. If “--- --- ---” is displayed, the new software is installed, checked and ready to be used.

Repeat steps 1 to 6 for each monitor to be upgraded.

When the upgrade key has performed as many upgrades as it was programmed to perform, return it to Philips for recycling. Please contact your nearest Philips Service Center for details.

# 15 Troubleshooting

---



## Introduction

Common problems that may occur during monitoring are dealt with in the relevant chapters in this book. This chapter describes:

- The Self Test
- The Quick Test
- The Parameter Test, including:
  - Ultrasound Test
  - Toco Test
  - IUP Test

---

## Self Test

- If a non-fatal error occurs (for example, if the batteries are low):
  - An error message is displayed for ten seconds.
  - **Err xxx** , time and date are printed on the paper after ten seconds, and after that every ten minutes. (“xxx” represents the number of the error message.)
  - Switch the monitor off and then on. If the error occurs again, try to solve the problem or, if you cannot, contact your Philips Service Engineer or Response Center.
-  If a fatal error occurs (for example, if a board is defective):
  - An error message is displayed for ten seconds.
  - After ten seconds, the monitor tries to restart.

---

## Quick Test

1. Remove any monitoring equipment plugged into the input sockets. If a telemetry receiver is switched on, switch it off or disconnect it and any external devices connected to the monitor.
2. Switch on the monitor and the recorder.
3. Press and release the test key. Check that:
  - The fetal displays flash alternately
  - The recorder on/off light blinks in time with the display
  - A test pattern is printed on the paper

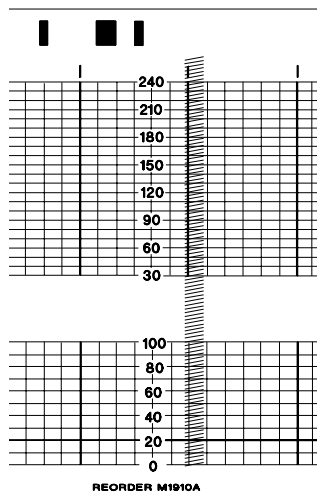

- Check the lines in this test pattern to ensure the heating elements on the printer head are operational. Lines printed on the colored grid lines may appear light, this is however not considered to be a fault.

If any of these checks fail, contact your Philips Service Engineer or Response Center.

The paper speed is automatically set to 3cm/min during the test and reset to its previous value afterwards.

If an error occurs:

- An error message is displayed for ten seconds.
- **Err xxx**  time and date are printed on the trace after ten seconds, and then every ten minutes.
- (“xxx” is the number of the error message.)

To stop the error annotation printing, switch the monitor off and then on. If the error is repeated, contact your Philips Service Engineer or Response Center.

---

## Parameter Test

The parameter test checks the signal path to and from the input sockets, but not the transducers or patient modules themselves. To carry out the test:

1. Switch on the monitor and the recorder.
2. Connect the appropriate transducer or patient module to each socket.
3. Press and hold the test key at the rear of the monitor **(3)**.

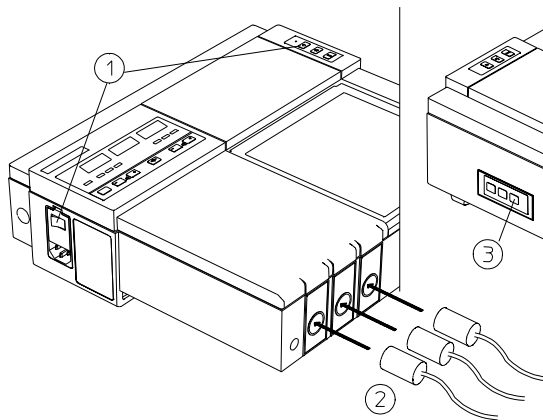

The correct monitor response for each signal is:

Signal	Correct Monitor Response
US1	<b>190</b> is displayed and printed. Signal quality indicator is green. Fetal heartbeat is heard from loudspeaker.
US2	<b>170</b> is displayed and printed. Signal quality indicator is green. Fetal heartbeat is heard from the loudspeaker.
Toco	A signal alternating between <b>10</b> and <b>60</b> is displayed and printed.
DECG using M1364A or M1357A	<b>200</b> is displayed and printed. Signal quality indicator is green. Fetal heartbeat is heard from loudspeaker.
MECG using M1364A or M1359A	<b>120</b> is printed. <b>MECG</b> is on.

If your monitor's response is different, contact your Philips Service Engineer or Response Center.

If an error occurs:

- An error message is displayed for ten seconds.
- **Err xxx**  time and date are printed on the paper after ten seconds, and then every ten minutes.  
(“**xxx**” is the number of the error message.)

To stop the error annotation printing, switch the monitor off and then on.



---

## Testing Transducers

If any of the following tests fail, repeat the test using another transducer. If it still fails, contact your Philips Service Engineer or Response Center.

### Toco

1. Switch on the monitor and the recorder.
2. Connect the transducer to the Toco socket.
3. Gently apply pressure to the pick-up button.

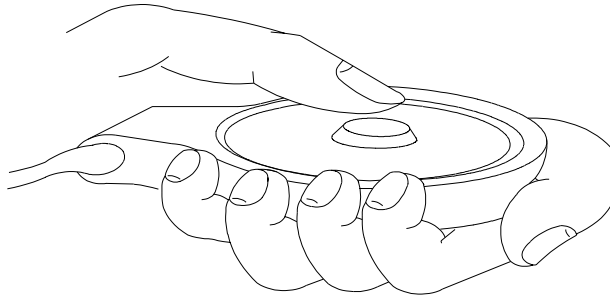

4. Check that the value on the display and paper shows this change in pressure.

### Ultrasound

1. Switch on the monitor and the recorder.
2. Connect the transducer to the US socket.
3. Increase the loudspeaker volume to an audible level.

4. Holding the transducer in one hand, move your other hand repeatedly towards and then away from the surface.

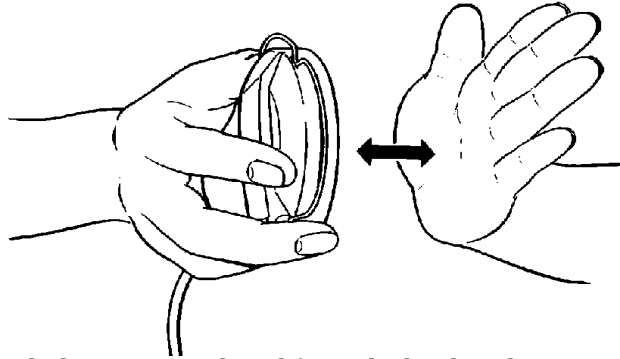

5. Check that a noise is heard from the loudspeaker.

## IUP

1. Switch on the monitor and the recorder.
2. Connect the transducer to the Toco socket.
3. Gently apply pressure to the syringe plunger.

Check that the value on the display and paper shows this change in pressure.

---

## Testing Patient Modules and Legplates

See the Service and Installation Guide for your monitor for details on testing patient modules and legplates.

---

## Testing a Barcode Reader

To check that the barcode reader is working correctly:

1. Scan *Test Barcode 1* and then *Test Barcode 2* on the barcode sheet with the barcode reader.
2. Check that **TEST OK5** is printed on the trace paper.

If **Test OK5** is not printed on the paper, disconnect the barcode reader and then reconnect it. Now repeat the test. If **TEST OK5** is still not printed, contact your Philips Service Engineer or Response Center.

---





## Error Messages

This section details error messages that are common to a number of parameters. See the Troubleshooting section at the end of the individual chapters for error messages specific to a parameter.

Error	Display	Cause	Solution
Err 1 <sup>1</sup>	US	Wrong transducer in the US socket	Connect the correct transducer
Err 1 <sup>1</sup>	ECG	Wrong transducer in the ECG socket	Connect the correct transducer
Err 2 <sup>1</sup>	Toco	Wrong transducer in Toco socket	Connect correct transducer
Err 4 <sup>1</sup>	US ECG	Wrong transducer connected	Connect correct transducer
Err 9	US Toco ECG	Invalid telemetry mode	Check the cable from the telemetry receiver and if, necessary, replace it

Error	Display	Cause	Solution
<b>Err 16</b>	US Toco ECG	Wrong pairing of telemetry and transducers	Either disconnect the transducers or switch off the telemetry receiver
<b>nop</b>	ECG	No contact, or poor contact, between reference electrode and mother	Use a new electrode

1. See Appendix D, “Accessories,” for a list of transducers that can be connected to the monitor.

Message	Cause	Solution
Err bAt <sup>1</sup>  <sup>2</sup>	Battery low or empty of charge	Change the batteries as soon as possible. If you do not change the batteries, your specific settings will return to their default values when the monitor is switched on. (For example, the date is set to 4.4.44.)
Err PAP	Incorrect type of paper loaded	Replace with recommended paper
Err PAP 30-240  <sup>3</sup> Err 602 <sup>4</sup>	Incorrect type of paper loaded	Load paper with 50-210 scale or change the monitor’s paper format setting (see the Service and Installation Guide for your monitor)
Err PAP 50-210  <sup>3</sup> Err 602 <sup>4</sup>	Incorrect type of paper loaded	Load paper with 30-240 scale or change the monitor’s paper format setting (see the Service and Installation Guide for your monitor)
Err xxx  <sup>3</sup>	xxx is between 500 and 600. This indicates a technical failure diagnosed by the monitor’s self test program.	Contact your Philips Service Engineer or Response Center

Message	Cause	Solution
Error 601  3	Paper speed error	<p>Check that correct paper is used.</p> <p>Check the speed by timing how long it takes for the paper to advance 1cm:</p> <p>60 seconds = 1cm/min  30 seconds = 2cm/min  20 seconds = 3cm/min</p> <p>Contact your Philips Service Engineer or Response Center if the speed is incorrect.</p>

1. Displayed for ten seconds when the monitor is first switched on.
2. Printed every 10 minutes.
3. Printed every three pages.
4. Displayed for 10 seconds.



# Care and Cleaning

---

## Introduction

This chapter gives you information about how to care for and clean your monitor and standard accessories. Many of the supplies and accessories have their own instructions. You must refer to these for full care and cleaning information. Always follow the manufacturer's directions carefully when cleaning any equipment. Damage caused by using substances not approved by Philips is not covered under warranty.

---

### Caution

**After cleaning, disinfecting and sterilizing the monitor and accessories, check them carefully. If you see signs of deterioration or damage, do not use the product for further measurements.**

---

---

## Cleaning the Monitor and Accessories

In the following section you will learn how to clean the monitor, transducers, patient modules, adapters and cables.

### DO NOT:

- Submerge any part of the fetal monitoring system
- Handle transducers or patient modules roughly. This could damage the cover, piezoelectric crystals and mechanical parts. Transducer covers are made of soft plastic; avoid contact with hard or sharp objects.
- Flex the cables excessively
- Allow cleaning solutions or transducers, adapters or patient modules to exceed a temperature of 45°C (113°F)
- Autoclave the transducers, adapters, patient modules and cables, or heat them above 60°C (140°F)
- Permit the blue Toco transducer's ventilated cable connector to become wet as liquid can enter the ventilation tube through capillary action.

***Note***—The Blue Ultrasound and Toco transducers are protected against the effects of continuous immersion in water according to IEC 529 IP 68.



## Cleaning

Keep the outside surfaces of the equipment clean and free of dust and dirt. Use a lint-free cloth, moistened with either soap and water or a diluted, non-caustic detergent or one of the approved cleaning agents listed below. Do not pour liquid on the monitor or allow any to enter the monitor case. Although the monitor is chemically-resistant to most common hospital cleaners and non-caustic detergents, alternative cleaners are not recommended and may stain the monitor. Never use an abrasive material such as steel wool or metal polish.

---

### **Warning**

**Philips makes no claims regarding the efficacy of the listed chemicals or methods as a means for controlling infection. Consult your hospital's Infection Control Officer or Epidemiologist for information on infection control.**

**For comprehensive details on cleaning agents and their efficacy refer to "Guidelines for Prevention of Transmission of Human Immunodeficiency Virus and Hepatitis B Virus to health care and public safety workers" issued by the US Department of Health and Human Services, Public Health Service, Center for Disease Control, Atlanta, Georgia, February 1989.**

---

## Cleaning Agents

This table lists the recommended cleaning agents for your fetal monitor and accessories.

	Mild soaps	Tensides	Alcohol-based	Aldehyde-based
Monitor	✓	✓	✓	✓
Brown Transducers	✓	✓	✓	✓
Blue Transducers	✓	✓	✓	✓
Belts	✓	✓	✓	✓
Patient Modules M1364A	✓	✓	✓	✓
ECG Adapter Cables M1362A, M1363A	✓	✓	✓	✓
ECG legplate adapter cable M1362B	✓	✓	✓	✓

Recommended cleaning agent brands are:

Tensides	Edisonite Schnellreiniger <sup>®</sup> , Alconox <sup>®</sup>
Ammonias	Dilution of Ammonia <3%, Window cleaner
Alcohol	Ethanol 70-80%, Isopropanol 70-80%, Window cleaner
Aldehyde-based	Cidex <sup>®</sup>

### Caution

**To avoid damage to the product, observe the following general precautions when cleaning unless instructed otherwise in the guidelines supplied with a specific product.**

Do not use strong solvents such as acetone or trichloroethylene. Always dilute according to the manufacturer's instructions, or use lowest possible concentration. Never use abrasive materials such as steel wool or silver polish. Never submerge any part of the system and do not allow liquid to enter inside the products. Wipe the cleaning agent off the surface of the equipment immediately with a damp cloth.

## Disinfecting

We recommend that you disinfect the equipment only when necessary as determined by your hospital's policy, to avoid long term damage. Never immerse or soak any part of the monitoring system. Do not allow the disinfectant to remain on the equipment. Remove it immediately by wiping with a cloth dampened with water. Clean the equipment before disinfecting it.

This table lists the recommended disinfecting agents for your fetal monitor and accessories

Product	Alcohol-based	Aldehyde-based
Monitor	✓	✓
Brown Transducers	✓	✓
Blue Transducers	✓	✓
Patient Modules M1364A	✓	✓
ECG Adapter Cables M1362A, M1363A	✓	✓
ECG legplate adapter cable M1362B	✓	✓

Recommended disinfecting agent brands are:

Aldehyde-based	Buraton liquid <sup>®</sup> , dilution of formaldehyde (3-6%), Cidex <sup>®</sup> , Gigasept <sup>®</sup> , Kohrsolin <sup>®</sup>
Alcohol-based <sup>1</sup>	Ethanol 70%, Isopropanol 70%, Cutasept <sup>®</sup> , Hospisept <sup>®</sup> , Kodan <sup>®</sup> -Tincture forte, Sagrosept <sup>®</sup> , Spitacid <sup>®</sup> , Sterilium fluid <sup>®</sup>

1. Only Ethanol 70% and Isopropanol 70% are tested and qualified

---

### **Caution**

**To avoid damage to the product, observe the following general precautions when disinfecting unless instructed otherwise in the guidelines supplied with a specific product.**

---

Do NOT use Povodine<sup>®</sup>, Sagrotan<sup>®</sup>, Mucovit<sup>®</sup> or strong solvents.

Do NOT use strong oxidants such as bleach

Do NOT use bleaches containing sodium hypochlorite

Do NOT use disinfectants containing iodine complexes

If you intend to use a cleaning agent not listed here, check its material compatibility first

ALWAYS dilute according to the manufacturer's instructions.

### **Sterilizing**

It is not possible to sterilize the monitor, transducers, patient modules or ECG cable adapters by means of autoclaving, gas treatment, formaldehyde process, or radiation. Do not use bleaches containing sodium hypochlorite (for example Clorox<sup>®</sup>) on any of the equipment.

Only ECG adapter cables M1362A and M1363A can be sterilized by autoclaving or by gas sterilization. We recommend that you sterilize only when necessary as determined by your hospital's policy, to avoid long-term damage to the cable. We also recommend that you clean the cables before sterilizing them. The M1362A and M1363A cables have been tested to withstand Ethylene Oxide (Et) gas sterilization. Be sure that all safety precautions regarding aeration after EtO exposure are followed. The cables are tested to withstand autoclaving at 136° maximum.

---

### **Belts**

Wash soiled belts with soap and water. Water temperature must not exceed 60°C (140°F).

---

## Storing Recorder Paper

Recorder paper is not intended for long-term archival storage. Another medium should be considered if this is required.

Dyes contained in thermal papers tend to react with solvents and other chemical compounds that are being used in adhesives. If these compounds come into contact with the thermal print, the print may be destroyed over time. You can take the following precautionary measures to help avoid this effect.

- Store the paper in a cool, dry and dark place.
- Do not store the paper at temperatures over 40°C (104°F).
- Do not store the paper where the relative humidity exceeds 60%.
- Avoid intensive light (UV light), as this may cause the paper to turn gray or the thermal print to fade.
- Avoid storing the thermal paper in combination with the following conditions:
  - Papers that contain organic solvents. This includes papers with tributyl and/or dibutyl phosphates, for example recycled paper.
  - Carbon paper and carbonless copy paper.
  - Products containing polyvinyl chlorides or other vinyl chlorides for example (but not exclusively) document holders, envelopes, letter files, divider sheets.
  - Detergents and solvents, such as alcohol, ketone, ester and others, including cleaning and disinfecting agents.
  - Products containing solvent-based adhesives such as (but not exclusively) laminating film, transparent film or labels sensitive to pressure.

To ensure long lasting legibility and durability of thermal printouts, store your documents separately in an air-conditioned place and use

- only plasticizer-free envelopes or divider sheets for protection.
- laminating films and systems with water-based adhesives.

Using such protective envelopes cannot prevent the fading effect caused by other, external agents.

---

## Preventive Maintenance

You must perform the following checks every 12 months to ensure that your monitor and accessories are in perfect working order.

### Visual Inspection

Before using any transducer, patient module, adapter cable or other accessories, you should inspect it carefully to ensure that all its components, such as the housing, cable, and connector are in good condition. If any part is broken or damaged you should not use it.

### Routine Inspection

Every 12 months, you must carry out a series of preventive maintenance tasks and performance assurance tests. These ensure that the monitor continues to perform at its best, and reduces the possibility of failures. The tasks to be carried out are listed in the following table. Where there are national regulations on the qualification of the testing personnel and suitable measuring and testing equipment, these must be observed.

Tasks and Tests
Replace the batteries
Carry out a mechanical inspection of the monitor
Check transducers, patient modules, cables, connectors and other accessories for cracks and defects
Carry out the Quick Test as described on page 114
Carry out the Parameter Test as described on page 115

## Mechanical Inspection

To carry out a mechanical inspection of the monitor:

- Make sure all exposed screws are tight
- Check the external cables and housings for splits, cracks or signs of twisting
- Replace any cables that show serious damage
- Make sure that the combined interface module, if fitted, is securely in place

---

## Calibration and Electrical Safety Checks

Perform electrical safety checks as described in the Service and Installation Guide for your monitor. The NIBP function (Series 50 IP-2 only) must be calibrated every 12 months. Refer to the service guide for your monitor for details about these checks.

---

## Disposal

Arrangements for the disposal of your monitor at the end of its working life should conform to your country's laws regarding the disposition of equipment containing electrical parts.

Disposal





## Safety Information

### Introduction

This appendix gives you safety information for patient, user, and monitor.

### General Safety Information

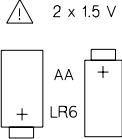
	<p>This symbol indicates that you should consult the <i>Instructions For Use</i> (this guide), and particularly any warning messages.</p>
	<p><b>Equipotential Terminal</b></p> <p>This symbol identifies terminals which are connected together, bringing various equipment or parts of a system to the same potential. This is not necessarily earth potential. The value of potentials of earth may be indicated adjacent to the symbol.</p>
	<p><b>Earth Terminal</b></p> <p>This symbol identifies the terminal for connection to an external protective earth system.</p>
	<p><b>Battery 2 x 1.5V</b></p> <p>This symbol identifies the battery holder containing two 1.5 V batteries.</p>

The monitor is designed to fulfil safety requirements according to IEC 60601-1, CSA-C22.2 No 601.1-M90, and additionally UL 544 for the Series 50A only.

It complies with the essential requirements of the Medical Device Directive 93/42/EEC. The monitor is classed:

**ORDINARY EQUIPMENT** - Enclosed equipment protected against ingress of water.

**CONTINUOUS OPERATION** - Can be operated continuously.

The Philips Series 50 A and the Philips Series 50 IP-2 are not “ECG-Monitors”, are not defibrillator-protected, and are not designed for direct cardiac application.





---

## Electrical Safety

### Series 50 A

Equipment	Equipment Type	Information
External Toco transducer (M1355A) Ultrasound transducer (M1356A)	B ⚡	Connecting the transducer to the Toco channel results in a B condition

## Series 50 IP-2

Equipment	Equipment Type	Information
External Toco transducer (M1355A)	CF 	Connecting the transducer to the Toco channel results in a CF condition
IUP quartz transducer (1290C) IUP pressure transducer (CPJ840J5)	CF 	Connecting the transducer to the Toco channel results in a CF condition
Ultrasound transducer (M1356A)	B 	Connecting the transducer to the US2/ECG channel results in a B condition
DECG transducer (M1357A) MECG transducer (M1359A) ECG only patient module (M1364A)	CF 	Connecting the transducers to the US2/ECG channel results in a CF condition

---

## ESU, MRI and Defibrillation

---

### Warning

**Remove all transducers, patient modules, sensors and accessories before performing electrical surgery, defibrillation and MRI. High frequency current can flow through the equipment and burn the skin.**

---

The equipment has not been tested with defibrillators.

---

## Leakage Current

Leakage current can be hazardous to the patient.

---

### Caution

**If the monitor is connected directly to other equipment, such as an additional patient monitor, or a second monitor is to be connected directly to the mother, you must carry out all relevant safety tests in accordance with safety standard IEC 60601-1-1.**

---

---

---

## Maximum Input/Output Voltages

### Service Socket for Upgrade Key

The service engineer can connect an industry standard compatible PC to this socket (1) to carry out various extended configuration and service functions. Maximum voltage is  $\pm 12V$ .

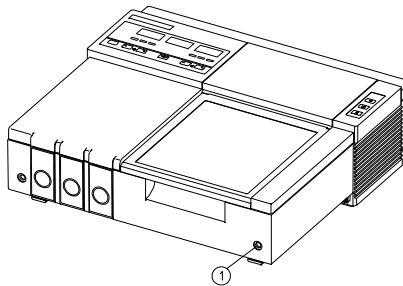

## Combined Interface Module

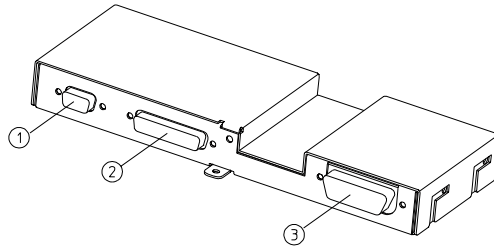

This table shows the interfaces available with the combined interface module, the option title and the maximum input/output voltages:

Device (Socket)	Option	Max. Output/Input Voltage
HBCR barcode reader (1)	J10	+ 5V except for Pins 2 and 3 which are $\pm 12V$
NIBP monitor (1)	J13 (with the label M1353-66531E)	
FSpO <sub>2</sub> monitor (1)	J14	
Fetal Telemetry (2)		+5V except for: Pins 14 and 15: $\pm 12V$ input Pin 2: -12V output Pin 3: +5V output Pin 4: +12V output
Philips Obstetrical Surveillance Systems (3)		$\pm 12V$ except for Pins 17, 18, 22 which are +5V input

## Modem Interface Module

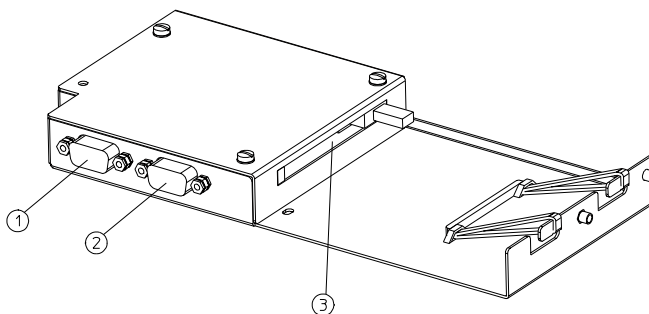

Device (Socket)	Option	Max. Input/Output Voltages
HBCR 8200 barcode reader <b>(1)</b>	J15	+5V except for: Pin 2 which is $\pm 12V$ input and Pin 3 which is $\pm 12V$ output
Auxiliary serial interface socket <b>(2)</b>	J15	+5V
PCMCIA modem port <b>(3)</b>	J15	+5V

---

## Protective Earth

To protect hospital personnel and the patient, the monitor's casing must be grounded. Accordingly, a 3-wire power cable grounds it to the power line ground when plugged into an appropriate 3-wire receptacle. Do not use a 3-wire to 2-wire adapter with the monitor. Any interruption of the protective earth grounding will cause a potential shock hazard that could result in serious personal injury.

Whenever it is likely that the protection has been impaired, the monitor

must be made inoperative and be secured against any unintended operation.

---

**Warning**

**Check each time before use that the monitor is in perfect working order and properly grounded.**

---

Position the patient cable so that it does not come into contact with any other electrical equipment. The cable connecting the patient to the monitor must be free of electrolyte.

Make sure that the monitor is free from condensation during operation. Condensation can form when equipment is moved from one building to another, and is exposed to moisture and differences in temperature.

---

**Warning**

**Possible explosion hazard if used in the presence of flammable anesthetics.**

---

---

## Environment

Use the monitor in an environment that is reasonably free from vibration, dust, corrosive or explosive gases, flammable agents, extremes of temperature, humidity and so forth. It operates within specifications at ambient temperatures between 0 and 55°C. Ambient temperatures that exceed these limits can affect the accuracy of the monitor and cause damage to the components and circuits. Only products that fulfil the necessary safety and electrical standards should be used in conjunction with the monitor (contact your local response center for details).

Allow at least 5cm (2in) clearance around the monitor for proper air circulation. If the monitor is mounted in a cabinet, allow sufficient space at the front for operation and at the rear for servicing with the cabinet door open.

---

## Spillage

If liquid accidentally enters the monitor through the maternal display recess, you must cease using the monitor immediately. Contact an authorized engineer for a safety inspection.

---

## Electromagnetic Compatibility

The electromagnetic compatibility (EMC) validation includes testing performed according to the international standard for EMC with medical devices. See the Manufacturer's Declaration for details.

## EMC Testing

---

### Caution

**If operating under conditions according to the EMC-standard 60601-1-2 (Radiated Immunity 3 V/m), field strengths above 1 V/m may cause erroneous measurements at various frequencies. Therefore it is recommended to avoid the use of electrically radiating equipment in close proximity to these measurements.**

---

During the test program the monitor was subjected to international standard and Philips proprietary EMC tests. During most of the testing no anomalies were observed. Some reduced performance was observed with the IEC 801-3 Radiated Immunity and IEC 801-4 Fast Transient/Bursts Immunity tests.

IEC 801-3 specifies that the product must be subjected to a field of 3V/m over a frequency range of 26 to 1000 MHz with no degradation of performance. At some of the test frequencies over the specified range anomalies were observed. For these test points the radiated field was reduced to the level at which the trace returned to normal. These reduced levels are shown in the following table.



Parameter	Sensor	Frequency Range	Immunity Level
IUP	M1333A	26 MHz to 1000 MHz	0.5V/m

IEC 801-4 specified that the product is subjected to high speed pulses up to 1000 V applied to the power cord and all I/O cables. During and after most of the test pulses, no anomalies were observed. However in rare cases the ultrasound channel had been triggered.

Parameter	Sensor	Burst Immunity Level
Ultrasound	M1356A	600 V

## System Characteristics

The phenomena discussed above are not unique to the monitor but are characteristic of patient monitors in use today. This performance is due to very sensitive high gain front end amplifiers used to process the physiological signals from the patient. Among the many similarly performing monitors already in use by customers, interference from electromagnetic sources is rarely a problem.

## Avoiding Interference

When electromagnetic interference (EMI) is encountered there are a number of things that can be done to mitigate the problem.

1. Eliminate the source. Possible sources of EMI can be turned off or moved away to reduce their strength.
2. Attenuate the coupling. If the coupling path is through the patient cables the interference may be reduced by moving and/or rearranging the cables to a different location of the monitor. If the coupling path is through the power cord, plugging the monitor into a different mains circuit may help.
3. Connect the equipotential terminal of the monitor to the corresponding terminal of your mains installation.

4. Add external attenuators. If EMI becomes an unusually difficult problem, external devices such as an isolation transformer or a transient suppressor may help. An Philips customer engineer can assist you in determining the need for external devices.

**C**

# Replacing Fuses and Batteries

---

## Introduction

This appendix tells you how to replace fuses and batteries.

---

## Replacing the Batteries

The monitor's internal clock is powered by two batteries that are located behind a panel at the rear of the recorder paper compartment. The average life span of these batteries is one year. We recommend replacing them during the annual preventative maintenance cycle. When the battery charge is low, the message *EFF BATT* is displayed, and  is printed on the recorder trace. When this happens, replace the batteries as soon as possible.

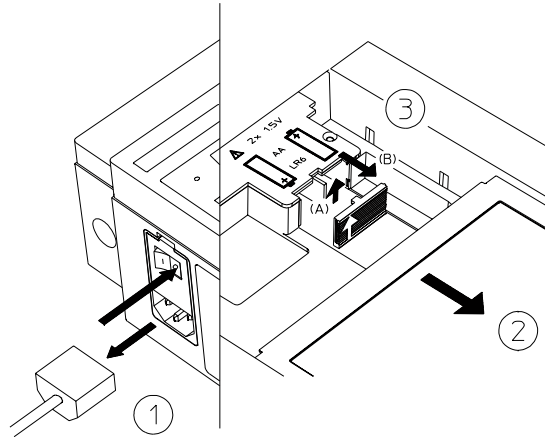

To replace the batteries:

1. Switch off the monitor and disconnect it from the mains supply.
2. Press the handle of the paper table and pull the table forward and open.
3. Lift out any paper.
4. Open the battery cover.
5. Replace the batteries with two alkaline AA size, LR6 type 1.5 Volt batteries.
6. Close the battery cover, load paper into the tray and push the paper tray closed.
7. Replace the mains supply and switch the monitor on.
8. Reset the time and date to prevent the wrong time and date from being printed on the recorder trace.

If the batteries are not replaced when necessary, the specific settings will return to their default values and will have to be reset each time the monitor is switched on. For example, the date is set to 4.4.44 and Toco baseline to 20 units. Leaking batteries could damage the monitor. If the monitor is not used for long periods, remove the batteries.

---

## Replacing the Fuses

Fuse values are printed beside the mains socket on your monitor:

For 100/120V  $\sim$  Line Voltage T500mA/250V

For 220/240V  $\sim$  Line Voltage T250mA/250V

( $\sim$  means “alternating current”)

To replace the fuses:

1. Switch off the monitor and disconnect it from the main power supply.
2. Using a flat-blade screwdriver, prise open the fuse cover **(A)**.

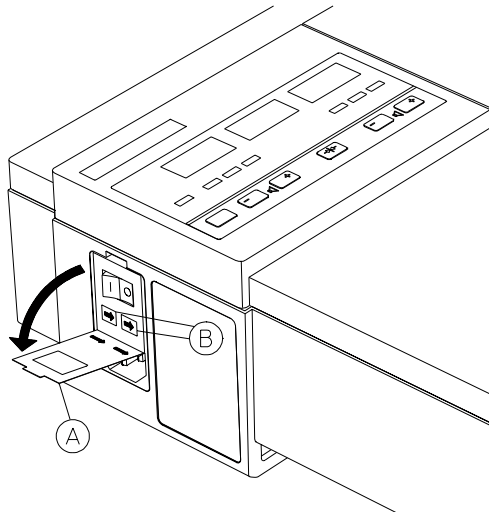

3. Lift the fuse holder **(B)** slightly and pull it out.
4. Remove the fuse from the holder and replace it with another of the correct value.
5. Slide the holder back into place, aligning the arrow on the holder with the arrow on the cover.
6. Repeat steps 3 and 5 for the second fuse.
7. Close the fuse cover.

## Replacing the Fuses

---

## Introduction

This appendix lists the accessories supplied as standard and as options. Items are subject to availability and this appendix is not, therefore, a definitive listing. Do not use accessories such as paper, or ultrasound gel that are not approved by Philips. You may damage the equipment and this type of damage is not covered by warranty.

---

## Standard Accessories

- Series 50 A* The following accessories are supplied as standard with the monitors:
- 1 x ultrasound transducer (M1356A) with the Single Ultrasound Model
  - 2 x ultrasound transducers (M1356A) with the Dual Ultrasound Model
  - 1 x Toco external transducer (M1355A)
  - 2 x reusable transducer belts
  - 3 x transducer knob adapters (M1356-43201)
  - 1 x bottle of gel
  - 1 x pack of paper
  - 1 x remote event marker (15249A)
  - 1 x power cord
  - 1 x Instructions for Use
  - 1 x Service and Installation Guide<sup>1</sup>

---

1. To be supplied on CD-ROM from summer 2002.

*Series 50 IP-2*

- 1 x ultrasound transducer (M1356A)
- 1 x Toco external transducer (M1355A)
- DECG legplate adapter cable (M1362B)
- 1 x MECC adapter cable (M1363A)
- 1 x patient module (M1364A)
- 5 x Fetal Scalp Electrodes
- 3 x reusable transducer belts
- 3 x transducer knob adapters (M1356-43201)
- Equipotential grounding cable:
  - 8120-2961 (USA)
  - 8120-4808 (Europe)
- 1 x bottle of gel
- 1 x pack of paper
- 1 x remote event marker (15249A)
- 1 x power cord
- 1 x Instructions for Use
- 1 x Service and Installation Guide<sup>1</sup>

---

1. To be supplied on CD-ROM from summer 2002.



## Options

The following accessories can also be supplied when the appropriate option is ordered.

Accessories	Option	Model
<b>Barcode Reader</b> , including a reader and barcode booklet. This requires Option J10 or J15.	H15	Series 50 A <i>and</i> Series 50 IP-2
<b>Combined Interface Module</b> for telemetry and obstetrical surveillance systems (e.g. Philips OB <b>TraceVue</b> ) and barcode reader	J10 <sup>1</sup>	Series 50 A <i>and</i> Series 50 IP-2
<b>Combined Interface Module</b> for telemetry and obstetrical surveillance systems (e.g. Philips OB <b>TraceVue</b> ), includes an interface cable M1350-61609. <ul style="list-style-type: none"> <li>for Dinamap 1846 or</li> <li>COLIN Press-Mate/Nippon Colin Listmini Model BP-8800 NIBP Monitor</li> </ul>	J13 <sup>1</sup>	Series 50 A <i>and</i> Series 50 IP-2
<b>Combined Interface Module</b> for telemetry and obstetrical surveillance systems (e.g. Philips OB <b>TraceVue</b> ), includes an interface cable M1353-61614 <ul style="list-style-type: none"> <li>for Nellcor OxiFirst™ Fetal Oxygen Saturation Monitor (N-400)</li> </ul>	J14 <sup>1</sup>	Series 50 A <i>and</i> Series 50 IP-2
<b>Modem Interface Module</b> allows the transmission of fetal trace data from a Series 50 A to a receiver (e.g., an OB TraceVue system)	J15 <sup>1</sup>	Series 50 A
<b>Fetal Movement Profile</b>	C02	Series 50 A <i>and</i> Series 50 IP-2
<b>IUP Pressure Transducer</b> (CPIJ840J5)	C07	Series 50 IP-2
<b>Disposable IUP Catheter</b> . This includes 1 x box M1333A (containing 10 catheters) disposable intrauterine sensor-tip pressure catheters and M1334A reusable connector cable	C08 <sup>2</sup>	Series 50 IP-2

1. Options J10, J13, J14 and J15 cannot be fitted at the same time

2. Not available in U.S.A or Japan

---

## Optional Accessories

Accessories	Option	Model
Service and Installation Guide	0B3	Series 50 A <i>and</i> Series 50 IP-2
Installation and Operating Guide Video <ul style="list-style-type: none"> <li>• VHS/NTSC</li> <li>• VHS/PAL</li> </ul>	0B5	Series 50 A <i>and</i> Series 50 IP-2
Wall mounting kit	1AB	Series 50 A <i>and</i> Series 50 IP-2
Paper take-up tray <sup>1</sup>	1AC	Series 50 A <i>and</i> Series 50 IP-2
Angled mounting kit	1AD	Series 50 A <i>and</i> Series 50 IP-2
Mobile cart	2AE	Series 50 A <i>and</i> Series 50 IP-2

1. Not compatible with the wall mounting kit.

---

## Paper

Use only the following types of paper:

Product Number	Country	FHR Scale	Color of Grid	kPa Scale	Highlighted 3cm Lines
M1910A	USA/Canada	30-240	Orange	No	Yes
M1911A	Europe/Japan	50-210	Green	Yes	No
M1913A	Japan	50-120	Green	No	Yes
M1913J	Japan	50-210	Green <sup>1</sup>	No	Yes

1. Normal bradycardia and tachycardia ranges alarm ranges are yellow; severe bradycardia and tachycardia ranges are red.

The paper is chemical/thermal, fanfold, with a labor scale of 0 to 100 units @ 25 units/cm. Each pack of paper has 150 numbered pages. Paper is supplied in cases of 40 packs.

Do not use paper with sprocket holes intended for HP 8040A/8041A fetal monitors as the trace may not be legible and a paper jam may occur.

---

## Gels

Using ultrasound gel that is not approved by Philips may reduce the signal quality and may damage the transducer. This type of damage is not covered by warranty.

**40483A** Aquasonic transmission gel for use with ultrasound transducers:

- Available worldwide
- Water/soluble
- Easy patient clean-up
- Supplied in packs of 12 oz (250 gr) bottles

- Shelf life: 24 months maximum; 6 months minimum.
- 40483B** 5-liter refill container to refill 40483A bottles.

---

## Heart Rate Transducers and Patient Modules

<i>Series 50 A and</i>	<b>M1355A</b>	Toco Transducer
<i>Series 50 IP-2</i>	<b>M1356A</b>	Ultrasound Transducer
<i>Series 50 IP-2</i>	<b>M1364A</b>	MECG/DECG patient module

---

## Electrodes and Cables

<i>Series 50 IP-2</i>	<b>M1362B</b>	DECG legplate adapter cable
	<b>M1363A</b>	MECG adapter cable
	<b>40493D</b>	Disposable pre-gelled electrode for abdominal ECG and for attaching the ECG leg plate adapter M1362B to the patient's thigh: <ul style="list-style-type: none"><li>• Silver/silver-chloride sensor</li><li>• Pre-gelled</li><li>• 54mm (2in) diameter</li><li>• Foam-backed</li><li>• Supplied in packs of 5</li><li>• (1 case = 4 boxes = 60 packs = 300 electrodes)</li><li>• Shelf life: 18 months maximum; 6 months minimum.</li></ul>
	<b>M1531B</b>	Electrode cable for MECG electrode 40493D: <ul style="list-style-type: none"><li>• Supplied in packs of 4.</li></ul>

---

## Disposable Scalp Electrodes

*Series 50 IP-2*    **15133D**    Available in Europe only

- Double spiral
- Driven by inner drive tube
- Gamma sterilized
- Supplied in packs of 25. Shelf life: 24 months maximum; 6 months minimum.

**15133E**    Available worldwide.

- Single spiral
- Driven by inner drive tube
- Radiation sterilized
- Supplied in packs of 50
- Shelf life: 24 months maximum; 6 months minimum.

---

## IUP Transducers

*Series 50 IP-2*    **CPJ840J5**

IUP pressure transducer, supplied with transducer holder CPJ84046. Use with sterile disposable domes CPJ84022.

---

## IUP Catheters

### **M1333A<sup>1</sup>**

Disposable intrauterine sensor-tip pressure catheter (5 mV/VmmHg  $\pm$  2% tolerance). Supplied in boxes of 10. M1353A Option C08 includes one box of catheters (M1333A) and one reusable connector cable M1334A.

- Radiation sterilized
- Contains 10 disposable catheters
- Shelf life 24 months maximum: 6 months minimum

Related products: M1334A reusable connector cable for use with M1333A catheter.

---

1. Not available in U.S.A. or Japan

---

## Domes

### **CPJ84022**

Sterile, disposable dome for use with IUP pressure transducer CPJ840J5.

- Supplied in packs of 50.
- Shelf life: 18 months maximum.

---

## IUP Transducer Holder

### **CPJ84046**

IUP Transducer holder

- For use with IUP pressure transducer CPJ840J5.
- Supplied in packs of four.

---

## Belts and Buttons

Reusable Abdominal Transducer Belt (M1562A)

- Pre-cut
- Width: 50mm
- Length: 1.3m
- Supplied in packs of 5.

Reusable Abdominal Transducer Belt (1500-0642)

- Pre-cut
- Width: 60mm
- Length: 1.3m
- Supplied in packs of 5.

Reusable Abdominal Transducer Belt (1500-0643)

## Belts and Buttons

- Width: 60mm
- 1 x 15m roll.

### Disposable Abdominal Transducer Belt (M2208A)

- Pre-cut
- Width: 60mm
- Length: 1.3 m
- Supplied in packs of 50.

### Reusable Leg Transducer Belt (M2209A)

- Pre-cut
- Width: 3,1 mm
- Length: 80 cm
- Supplied in packs of 50.

### Belt Buttons (M1569A)

- Supplied in packs of ten.

### Transducer Knob Adapter (M1356-43201)

- Supplied in packs of three.



---

## Barcode Booklets

Labels, cards, and instructions on how to customize sheets of nursing notes.

English M1350-9071~~X~~<sup>1</sup>

French M1350-9072~~X~~

German M1350-9073~~X~~

Dutch M1350-9074~~X~~

Spanish M1350-9075~~X~~

Italian M1350-9076~~X~~

Japanese M1350-9080~~X~~

---

## Modem Interface Module Barcode Sheet

*Series 50 A* Multi-language barcode package (M1350-9071~~X~~) for all countries in which modem interface module is available.

---

## Digital Interface Protocol Specifications

Programmer's guide (M1350-90114) describing data exchange between Series 50 Fetal Monitor and a PC host station/OB information management system.

---

1. The suffix "X" represents the current revision.



# Manufacturer's Information

---

## Manufacturer's Responsibility

Philips Medical Systems only considers itself responsible for any effects on safety, reliability and performance of the equipment if:

- Assembly operations, extensions, re-adjustments, modifications or repairs are carried out by persons authorized by Philips, and
- The electrical installation of the relevant room complies with national standards, and
- The instrument is used in accordance with the instructions for use.

---

## Warranty

Philips hardware products are warranted against defects in materials and workmanship. If Philips receives notice of such defects during the warranty period, Philips shall, at its option, either repair or replace hardware products which prove to be defective. Some newly manufactured products may contain selected remanufactured parts equivalent to new in performance.

Philips software and firmware products which are designated by Philips for use with a hardware product, when properly installed on that hardware product, are warranted not to fail to execute their programming instructions due to defects in materials and workmanship. If Philips receives notice of such defects during the warranty period, Philips shall repair or replace software media and firmware which do not execute their programming instructions due to such defects. Philips does not warrant that the operation of the software, firmware or hardware shall be uninterrupted or error free.

If Philips is unable, within a reasonable time, to repair or replace any

product to a condition as warranted, Customer shall be entitled to a refund of the purchase price upon return of the product to Philips.

**1. Duration and Commencement of Warranty Period**

The warranty period for each product is specified in the table below, depending upon the warranty classification code of the product at time of order. The applicable warranty code shall be specified on the Philips Price List. The warranty period begins either on the date of delivery or, where the purchase price includes installation by Philips, on the date of installation. If Customer schedules or delays installation more than thirty (30) days after delivery, the warranty period begins on the thirty-first (31st) day from the date of delivery.

<b>Product</b>	<b>Warranty period</b>
Series 50 A (M1351A) Antepartum Fetal Monitor	5 years from date of shipment
Series 50 IP-2 (M1353A) Intrapartum Fetal Monitor	1 year from date of shipment
M1355A External Toco Transducer	1 year from date of shipment
M1356A Ultrasound Transducer	1 year from date of shipment
M1364A ECG patient module	1 year from date of shipment

**2. Place of Performance**

Within Philips service travel areas, warranty and installation services. For products installed by Philips and certain other products designated by Philips will be performed at Customer’s facility at no charge. Outside Philips service travel areas, warranty and installation services will be performed at Customer’s facility only upon Philips’s prior agreement and Customer shall pay Philips’s round trip travel expenses and applicable additional expenses for such services.

On-site warranty services are provided only at the initial installation point. If products eligible for on-site warranty and installation services are moved from the initial installation point, the warranty will remain in

effect only if Customer purchases additional inspection or installation services at the new site.

For product warranties requiring return to Philips, products must be returned to a service facility designated by Philips. Portable products (battery powered) and products purchased under Philips's international prices can be returned to the closest authorized Philips repair depot worldwide. All other products with return to Philips warranty must be returned to one of the authorized repair depots within the country of original purchase. Customer shall prepay shipping charges (and shall prepay all duty and taxes) for products returned to Philips for warranty service. Except for products returned to Customer from another country, Philips shall pay for return of products to Customer.

Installation and on-site warranty services outside the country of initial purchase are included in Philips's product price only if Customer pays Philips international prices (defined as destination local currency price or Export price). Service outside the country of initial purchase is subject to the conditions regarding Philips service travel areas and initial installation point described above.

### 3. Limitation of Warranty

The foregoing warranty shall not apply to defects resulting from:

- a. Improper or inadequate maintenance by Customer;
- b. Customer-supplied software or interfacing;
- c. Unauthorized modification or misuse;
- d. Operation outside of the environmental specifications for the product; or
- e. Improper site preparation and maintenance.

TO THE EXTENT ALLOWED BY LOCAL LAW, THE WARRANTY SET FORTH ABOVE IS EXCLUSIVE AND NO OTHER WARRANTY, WHETHER WRITTEN OR ORAL, IS EXPRESSED OR IMPLIED AND PHILIPS SPECIFICALLY DISCLAIMS THE IMPLIED WARRANTIES OF MERCHANTABILITY AND FITNESS FOR A PARTICULAR PURPOSE

### 4. Australia and New Zealand Only

For consumer transactions the warranty terms contained in this statement, except to the extent lawfully permitted, do not exclude, restrict or modify and are in addition to the mandatory statutory rights applicable to the sale of this product to you.

## USA Law

United States federal law restricts this device to sale by or on the order of a physician.

---

### **Caution**

**failure on the part of the responsible individual hospital or institution employing the use of this equipment to implement a satisfactory maintenance schedule may cause undue equipment failure and possible health hazards.**

---

## Specifications

The following section gives the manufacturer's specification for the monitor.

### Patient Safety

The monitor is designed to comply with:

- IEC 60601-1
- UL 544
- CSA-C22.2 No 601.1-M90

Parameter	Input Connector	Resulting Isolation
Toco (M1355A)	B	B
US (M1356A)	B	B
DECG (M1357A)	B	CF
MECG (M1359A)	B	CF
DECG or MECG via M1364A	B	CF
IUP (M1333A) <b>Series 50 A</b> <b>Series 50 IP-2</b>	CF	CF
	B	CF
IUP (CPJ840J5)	CF	CF

None of the ECG modes are electrosurgery proof.

## Operating and Environmental

<b>Power Requirements</b>	Operating Voltage	100 - 120 V ( $\pm 10\%$ ) or 220 - 240 V ( $\pm 10\%$ )
	Line Frequency	50 to 60 Hz
	Power Consumption	25 VA max
	Battery Type	2 x 1.5V (AA size)
<b>Environment</b>	Operating Temperature	0°C to + 55°C
	Storage Temperature	-40°C to + 75°C
	Transducer Storage Temperature	-40°C to + 60°C
	Relative Humidity	5% to 95%°
<b>Dimensions and Weight without J options or transducers</b>	Height	115 mm (4.5in)
	Width	340mm (13.4in)
	Depth	308mm (12.1in)
	Weight	5.7kg (12.6lb)

<b>Heart Rate Range</b>	US	50 to 240 bpm
	DECG (Series 50 IP-2 only)	30 to 240 bpm
	ECG (Series 50 IP-2 only)	30 to 240 bpm
<b>Labor Activity</b>	External Toco Range	0 to +127 relative units
	IUP Range (Series 50 IP-2 only)	-99 to +127 mmHg or -9.9 to +16.9 kPa



<b>Audible Indications</b>	
Bradycardia Alert Range <sup>1</sup>	60-120 bpm
Tachycardia Alert Range <sup>1</sup>	150-210 bpm
Bradycardia Alert Delay <sup>1</sup>	10-300 sec
Tachycardia Alert Delay <sup>1</sup>	10-300 sec
NST Time Range	10-60 min

1. Not available in USA

---

## Ultrasound, External and Internal Toco

<b>Ultrasound Mode</b>	System	Pulsed Doppler oscillator
	Frequency	998.4kHz
	Repetition Rate	3.2kHz
	Ultrasound Intensity	1.5mW/cm <sup>2</sup> average for each of the seven active surfaces (using M1356A transducer)
<b>External Labor</b>	Signal Range	0 to 100 units
	Offset Compensation	±200 units
<b>Intrauterine Pressure</b>	Signal Range	-99 to +127mmHg
	Patient Leakage Current	10µA. Displayed pressure unit mmHg.
	Sensitivity	Automatically selectable between 40µV/V/mmHg (M1348A) and 5µV/V/mmHg (M1334A and CPJ840J5)

---

## Recorder

Recorder mechanism: 5 channel, high resolution (8 dots per mm, 200 dots per inch) thermal array recorder, paper end detection. Paper speeds 1, 2 and 3cm/min.

Annotation: time of day and date (automatic annotation every 10 minutes), paper sensing mode (annotated with each alteration of parameter).

Paper advance speed: 24cm/min. Automatic stop at perforation line.

## Scales

	Heartrate		Uterine activity (Toco) scale
	Scale A (M1910A)	Scale B (M1911A, M1913A, M1913J)	
<b>Vertical Scale Size</b>	7cm	8cm	4 cm
<b>Vertical Scale Sensitivity</b>	30 bpm/cm	20 bpm/cm	25 units/cm
<b>Range</b>	30 to 240 bpm	50 to 210 bpm	0 to 100 units

Z-fold paper with numbered pages

Recording times per pack:

8h 20min at 3cm/min

12h 30min at 2cm/min

25h at 1cm/min

Fetal Movement Profile (FMP) recording:

2 mm high bars on upper Toco scale

## Testing Facilities

Test button: With no front end connections to the instrument a thorough instrument test is performed including a display and recorder test. With the appropriate transducer connected the respective mode can be tested. See Chapter 15, "Troubleshooting," for instructions.

---

## Declaration



These medical devices comply with the requirements of the Medical Devices Directive (93/42/EEC) concerning medical devices.

This product is classified as Class IIb in accordance with Annex IX of the Medical Devices Directive (93/42/EEC).

Manufactured by: Philips Medizinsysteme Boeblingen GmbH  
Hewlett-Packard Str. 2, Boeblingen,  
Germany

Product Name: Fetal Monitor Series 50 A/IP-2

Model Numbers: M1351A and M1353A

Standards complied with:

Safety, Performance EN60601-1:1990+A1:1993+A2:1995

EMC EN60601-1-2:1993

## A

### Accessories

- optional, 149
- standard, 147

### Acknowledging an FHR

- alert, 87

### ACOG technical bulletin, 22

### After monitoring, 17

### Alerting

- FHR, 87

### Arrhythmia logic

- changing setting, 50
- what is it?, 51

## B

### Barcode

- deleting an entry, 94
- recording a note, 93

### Barcode booklets, 157

### Barcode reader

- twins offset, 60

### Barcodes

- use with modem interface module, 101

### Baselines

- separating, 59

### Batteries, replacing, 143

### Belt

- cleaning, 128
- fastening, 11, 12
- fixing button, 11
- fixing patient module to, 13

### Belts

- different types of, 155

## C

### Calibration check, 131

### Caring for your monitor, 125

### Cleaning

- belts, 128
- cables, 124
- monitor, 124, 125
- Patient modules, 124
- Transducers, 124

### Cleaning agents

- recommended, 126

### Clock key, 24

### Combined Interface Module, 73

### Cross channel

- verification, 84
- twins, 55

## D

### Date

- setting, 24

### DECG

- attaching the electrode, 40
- contraindications, 37
- troubleshooting, 52

### DECG legplate transducer

- using the SafeConnect system, 44

### DECG monitoring

- traditional open-wire method, 41

### DECG patient module

- using the SafeConnect system, 47

- using the traditional method, 42

### Defibrillation, 135

### Digital Interface

- Protocol Specifications, 157

### Disinfecting monitoring equipment, 127

### Display panel

- keys, 8

### Disposable scalp

- electrodes, 153

### Disposal, 131

### Domes, types of, 155

## E

### ECG patient module

- monitoring MECG, 82

### Electromagnetic

- compatibility, 140

### Electrical safety, 134

### Electrical safety check, 131

### Electrical safety test, 131

### Electrical surgery, 135

### Electromagnetic

- Interference, 141

### Environment, 139

### Equipotential grounding

- point
- connecting to earth potential, 20

### Error messages, 119

### ESU, 135

### Event marker

- key, 15
- remote, 15

### External devices

connecting to your monitor, 73  
recording NIBP, 71  
supported, 72  
trace display, 74

## F

**Fetal demise, suspected**, 14

### **Fetal movement**

detecting, 32  
FMP, 32  
twins, 32

### **FHR**

and Doppler flow measurements, 29  
distinguishing from MHR, 50  
monitoring twins, 55  
monitoring using DECG, 37  
monitoring using ultrasound, 29  
troubleshooting, 35

**FHR alerting**, 87  
changing alert limits, 88  
turning on and off, 88

### **FMP**

activity blocks, 32  
and fetal telemetry, 34  
and twins, 32  
sample trace, 32  
statistics, 34  
switching on and off, 33

### **FSpO<sub>2</sub>**

recording from external device, 71

### **FSpO<sub>2</sub>**

example trace, 77

introduction, 77  
troubleshooting, 78  
**Fuses, replacing**, 145

## I

**Intrauterine pressure. See IUP**

### **IUP**

connecting transducer to monitor, 67  
monitoring, 67  
zeroing the monitor, 68

### **IUP transducer**

testing, 118

## L

**Leakage current**, 136

## M

### **Maintenance**

calibration check, 131  
mechanical inspection, 131  
preventive, 130  
routine inspection, 130  
visual inspection, 130

**Manufacturer's responsibility**, 159

### **Maternal ECG**

applying electrodes, 82  
See MECC  
starting monitoring, 82

### **Maternal heart rate**

measurement problems, 85

**Maternal NIBP. See NIBP**

**Maximum input/output voltages**, 136

### **MECC**

electrodes, 152

### **MNIBP**

example trace, 76  
paper speed, 75  
recording, 71  
trace statistics, 76

### **Modem Interface Module**

Barcode Sheet, 157  
clearing trace memory, 103  
connecting peripheral devices, 98  
connecting the barcode reader, 98  
connecting to the telephone system, 99  
connecting to your monitor, 97  
displaying memory, 104  
entering data, 101  
error messages, 106  
PCMCIA card modem, 100  
setting patient information, 102  
stopping storage, 104  
storing data, 101  
storing fetal trace data, 104  
transmitting data, 105

### **Monitor**

cleaning, 125  
disposal of, 131  
fitting to a wall, 25  
fitting to the angle mount, 26  
fitting to the cart, 27

**Mounting solutions. See Monitor fitting**

**Monitor fitting**

**MRI**, 135

## N

### **NIBP**

- calibration check, 131
- recording from external device, 71

### **Non stress test**

- See NST

### **NST**

- setting the timer, 91

## O

### **OB TraceVue**

- transmitting fetal trace data to, 105

### **Obstetrical surveillance systems**

- trace display, 74

### **Operating and environmental information**

- 164

### **Optional accessories**, 149

## P

### **Paper**

- loading, 21
- removing, 21
- tearing off a trace, 23
- types, 151
- when to reload, 22

### **paper**

- storing, 129

### **Paper Out Alert**, 22

### **Paper speed**, 22

- changing, 22
- default, 22
- recording MNIBP, 75

- setting, 22

### **Paper take-up tray**, 28

### **Parameter test**, 115

### **Parts and keys**, 5

### **Patient module**

- connecting to monitor, 13

### **Patient modules**

- connecting to monitor, 13
- fixing to belt, 13
- monitoring MECG, 82

### **Patient safety**, 134

### **PCMCIA card modem**, 100

### **Power failure**

- and fetal trace transmission, 108

### **Power supply**

- voltage range, 19

### **Preventive maintenance**, 130

### **Protective earth**, 138

## Q

### **Quick test**, 114

- test pattern, 114

## R

### **Recognizing an FHR alert**, 87

### **Recorder**

- keys, 5
- specifications, 166
- switching on, 23

### **recorder**

- paper storage, 129

### **Recording a note**, 93

### **Redux creme**, 41

### **Remote event marker**, 15

### **Replacing batteries**, 143

### **Replacing fuses**, 145

## S

### **SafeConnect DECG adapter**, 44

### **SafeConnect DECG leg plate adapter cable**, 47

### **Safety**

- avoiding condensation, 139
- protective earth, 138

### **Scalp electrodes, disposable**, 153

### **Self test**, 113, 167

### **Separating twin traces**, 59

### **Signal quality**

- during monitoring, 14

### **Specifications**, 163

### **specifications**

- recorder, 166

### **Spillage**, 140

### **Spiral electrode**

- attaching, 40
- removing, 51

### **Standard accessories**, 147

### **Sterilizing monitoring equipment**, 128

### **Suspected fetal demise**, 14

### **Switching on the recorder**, 23

## T

### **Testing**

- IUP transducer, 118
- parameter test, 115
- quick test, 114
- self test, 167
- self-test, 113

transducers, 117

## **Time**

setting, 24

## **Toco**

baseline key, 67  
external monitoring, 66  
interuterine monitoring, 67  
testing a transducer, 117  
troubleshooting, 68  
zeroing the monitor, 67

## **Transducer adapter**

button, 13

## **Transducer knob**

adapter, 156

## **Transducer testing**, 117

Toco, 117  
ultrasound, 117

## **Transducers**

accessories, 152  
avoiding immersion, 14  
cleaning, 124  
connecting to monitor, 13  
fixing to belt, 12  
immersion, 30  
testing, 117, 118

## **Transmitting data**

modem interface  
module, 105

## **Troubleshooting**

DECG, 52  
FSpO<sub>2</sub>, 78  
IUP, 68  
MHR measurement  
problems, 85  
Modem Interface  
Module, 106  
monitoring twins, 63  
Toco, 68  
ultrasound, 35

## **Twins**

and FMP, 32  
cross channel verification, 55  
difference in heart rate  
traces, 56  
invasive monitoring, 56  
monitoring FHR, 55  
offsetting baselines, 59  
separating traces, 59  
troubleshooting, 63  
**Twins offset**, 59  
understanding the trace, 61

## **U**

### **Ultrasound**

applying gel, 31  
monitoring FHR, 29  
testing a transducer, 117  
trace delay, 29  
troubleshooting, 35

### **Upgrade key**

service socket, 136

### **Uterine activity**

example trace, 67  
monitoring, 66  
monitoring externally, 65  
monitoring internally, 65, 66  
troubleshooting, 68

### **Uterine pressure**

monitoring, 67

## **V**

### **Voltage setting**, 19

## **W**

### **Warranty**, 159

## **Z**

### **Zeroing the monitor**

See Toco